

# SYSTEMATICS OF THE *CAREX JAMESII* COMPLEX (CYPERACEAE: SECT. *PHYLLOSTACHYAE*)

Robert F. C. Naczi

Claude E. Phillips Herbarium  
Dept. of Agriculture & Natural Resources  
Delaware State University  
Dover, DE 19901-2277, U.S.A.  
rnaczi@dsc.edu

Bruce A. Ford

Department of Botany  
University of Manitoba  
Winnipeg, Manitoba  
R3T 2N2, CANADA  
bford@cc.umanitoba.ca

## ABSTRACT

Analyses of morphologic, geographic, and ecologic data indicate three species comprise the *Carex jamesii* complex: *C. jamesii*, *C. juniperorum*, and *C. timida*, sp. nov. *Carex jamesii* has shoot bases lacking red-purple, relatively tall culms, relatively long staminate portions of spikes, and relatively long perigynium beaks. It is common and widespread in mesic deciduous forests in much of the eastern U.S.A. and in southwestern Ontario. *Carex juniperorum* has red-purple shoot bases, short culms, short staminate portions of spikes, and short perigynium beaks. It is rare and has a disjunct distribution in mesic deciduous and deciduous-juniper forests and forest edges in the eastern U.S.A. and southeastern Ontario. *Carex timida* has red-purple shoot bases, tall culms, short staminate portions of spikes, and short perigynium beaks. It is rare and has a disjunct distribution in mesic deciduous forests of the eastern U.S.A. Phylogenetic analysis of morphologic data indicates the complex is monophyletic and *C. juniperorum* is the sister species of *C. timida*. The correct name and authorship of the section to which the *C. jamesii* complex belongs is determined to be *Carex* section *Phyllostachyae* Tuck. ex Kük. Synonymies, typifications, descriptions, and citations of representative specimens are provided for each species, along with an identification key.

## RESUMEN

Los análisis de datos morfológicos, geográficos, y ecológicos indican que el complejo *Carex jamesii* comprende tres especies: *C. jamesii*, *C. juniperorum*, y *C. timida*, sp. nov. *Carex jamesii* tiene las bases de los renuevos que no son rojo-púrpura, culmenes relativamente altos, parte estaminada de las espigas relativamente largas, y picos del utrículo relativamente largos. Es común y está distribuido en los bosques deciduos mesófilos en gran parte del este de U.S.A. y en el suroeste de Ontario. *Carex juniperorum* tiene las bases de los renuevos rojo-púrpura, culmenes cortos, parte estaminada de las espigas corta, y picos del utrículo cortos. Es raro y tiene una distribución disyunta en los bosques deciduos mesófilos y enebrales, y bordes de bosques en el este de U.S.A. y sureste de Ontario. *Carex timida* tiene las bases de los renuevos rojo-púrpura, culmenes altos, parte estaminada de las espigas corta, y picos del utrículo cortos. Es raro y tiene una distribución disyunta en los bosques deciduos mesófilos del este de U.S.A. El análisis filogenético de datos morfológicos indica que el complejo es monofilético y que *C. juniperorum* es la especie hermana de *C. timida*. El nombre correcto y autoría de la sección a la que pertenece el complejo *C. jamesii* se determina que es *Carex* sección *Phyllostachyae* Tuck. ex Kük. Se ofrecen sinonimias, tipificaciones, descripciones, y citas de especímenes representativos de cada especie, junto con una clave de identificación.

## INTRODUCTION

*Carex* section *Phyllostachyae* Tuck. ex Kük. is a morphologically distinctive group of sedges endemic to North American forests and forest openings. The

large and often leaf-like pistillate scales are the most striking feature of these plants. Additional traits common to the members of this group are densely caespitose habit; winged culms and peduncles, both of which are dilated at their apices; androgynous spikes, with lateral ones usually arising from the plant base; and beaked perigynia with entire orifices. Various workers (e.g. Crins 1990; Starr & Ford 1995; Naczi et al. 1998) have used the unusual morphologic features of *Carex* sect. *Phyllostachyae* to suggest the section is monophyletic, a hypothesis recently supported by molecular data (Starr et al. 1999). Recently, several authors have focused on various aspects of the systematics of *Carex* sect. *Phyllostachyae*, including phylogeny (Crins 1990; Starr et al. 1997, 1999), taxonomy (Catling et al. 1993; Naczi & Ford 1998; Naczi et al. 1998), genetic diversity (Ford et al. 1998a, 1998b, 1998c), chromosome numbers and arrangements (Naczi 1999), and anatomy and micromorphology (Starr & Ford 2001).

Ten species belong to *Carex* section *Phyllostachyae*: *C. backii* Boott; *C. basiantha* Steud.; *C. jamesii* Schwein.; *C. juniperorum* Catling, Reznicek, & Crins; *C. latebracteata* Waterf.; *C. saximontana* Mack.; *C. superata* Naczi, Reznicek, & B.A. Ford; *C. willdenowii* Willd.; *C. sp. nov.* Saarela & B.A. Ford; and one species described as new in this paper. The greatest species diversity occurs in the southeastern United States, where as many as five of these species are sympatric in portions of Alabama, Arkansas, and Tennessee.

One of the clades we have identified within *Carex* section *Phyllostachyae* is the *C. jamesii* complex (Naczi & Ford 1998; Starr et al. 1999). We hypothesize that this clade contains three species, *C. jamesii*, *C. juniperorum*, and an undescribed species here named *C. timida*. In this paper, we test this hypothesis by examining the systematics of the *C. jamesii* complex. This is the first of two papers exploring the systematics and genetic diversity among taxa in the *C. jamesii* complex.

#### MATERIALS AND METHODS

We studied the morphology, geography, and ecology of the *C. jamesii* complex in the field on numerous trips during 1986–2001. The field work included observations at sites throughout most of the geographic range of this complex. These sites were in Ontario, Canada, and 13 states of the eastern United States: Alabama, Arkansas, Illinois, Kentucky, Maryland, Michigan, Mississippi, Missouri, Ohio, Oklahoma, Tennessee, Virginia, West Virginia.

For this project, we studied over 1,950 specimens from the following 27 herbaria: BERA, BLH, DHL, DOV, EKY, IBE, KNK, KY, MICH, MO, MT, MU, MUR, NA, NY, OS, PENN, PH, TENN, US, VDB, VPI, WIN, WIS, WKU, ctb, bas. Abbreviations of herbaria are those of Holmgren et al. (1990) except for Charles T. Bryson herbarium (ctb) and Bruce A. Sorrie herbarium (bas).

#### **Morphology**

For the study of morphology, we selected 74 specimens as a representative sub-

set to measure for univariate and multivariate statistical analyses. We chose mature, complete, and ample specimens that exhibited the full range of morphologic variation of the *C. jamesii* complex and that originated from throughout the geographic range of the complex. We measured 16 continuous and two discrete characters on each of these specimens (Table 1). Each specimen we measured is denoted by a superscript asterisk in the specimen citations below.

To detect groups among the specimens and identify the characters that best diagnose these groups, we used principal components analysis (PCA). Before conducting the analysis, we standardized all measurements so each variable would have a mean of 0 and a standard deviation of 1. For the PCA, we included only continuous characters. To avoid weighting characters, we excluded characters that are probably genetically redundant. To detect such characters, we checked the Pearson correlation coefficient for all pairs of characters, and regarded values of the correlation coefficient  $\geq 0.7$  as indicating possibly genetically redundant characters. Exclusion of seven genetically redundant characters and two discrete characters resulted in the remaining nine characters being included in the PCA (Table 1).

We assessed the degree to which the groups detected in the PCA differed among themselves, character by character, by analyzing each of the measured variables with one-way analysis of variance (ANOVA) with the Tukey Honestly Significantly Different test for multiple comparisons of means. Because the variances of several variables are heterogeneous (as determined by the Bartlett chi-square test for homogeneity of group variances), we transformed these data with the common logarithm before conducting the ANOVA. We performed all statistical analyses with SYSTAT version 5.1 (Wilkinson 1989) on an Apple® computer.

In order to apply the available names to the groups revealed through PCA and ANOVA, we studied type specimens. Isotypes of *C. steudelii* Kunth were unsuitable for measuring because of their immaturity. We ascertained the application of this name by comparison of its isotypes with the specimens of the PCA and ANOVA groups. We applied all other names by inclusion of type specimens in the PCA and ANOVA.

### **Geography**

To determine the geographic range of each of the groups identified in the morphologic studies, we used herbarium specimen collection data to plot their distributions on outline maps. Each point on these maps is based on at least one herbarium specimen.

### **Ecology**

For each population encountered in the field, we noted vascular plant associates. Closely associated vascular plant species are those that grew within 10 m of a plant of the *C. jamesii* complex at more than one-third of all sites investigated for this study. We also surveyed all localities for additional members of

TABLE 1. Morphologic characters, with their abbreviations, measured on herbarium specimens of the *Carex jamesii* complex. The 9 characters marked with asterisks are those included in the principal components analysis.

---

#### Continuous Characters

1. Height of tallest culm, including terminal spike (CLMHT)\*
2. Height of shoot bearing tallest culm (SHTHT)\*
3. Width of widest leaf blade (WLFW)
4. Length of longest (per specimen) staminate portion of terminal spike (MSPL)
5. Length of peduncle of longest (per specimen) staminate portion of terminal spike (MPDCLL)\*
6. Length of proximalmost staminate scale of terminal spike (MSCL)\*
7. Length of longest (per specimen) scale subtending proximalmost perigynium of terminal spike (LFSCS)\*
8. Width of hyaline margin of scale subtending distalmost perigynium of terminal spike (MARGW)\*
9. Length of perigynium (PERIGL)\*
10. Width of perigynium (PERIGW)\*
11. Length of perigynium beak (PERIGBKL)
12. Length of achene (ACHNL)
13. Width of achene (ACHNW)
14. Height of culm/height of shoot (RCLM)
15. Length of proximalmost staminate scale/length of longest (per specimen) staminate portion of terminal spike (RSC)\*
16. Length of perigynium beak/length of perigynium (RBK)

#### Discrete characters

17. Number of leaves and bracts on shoot bearing tallest culm (LFNO)
  18. Number of perigynia in terminal spike (PERIGNO)
- 

the complex. We consider species of the complex found within 30 m of each other to be examples of syntopy.

#### Phylogeny

We compared members of the *C. jamesii* complex with each other and with other species in section *Phyllostachyae* in an attempt to discover morphologic characters useful for phylogenetic analysis. We polarized character states using members of sect. *Phyllostachyae* that constitute the "wide-scaled clade." Four species comprise this clade: *C. backii*, *C. latebracteata*, *C. saximontana*, and an undescribed species similar to *C. saximontana* (*C. sp. nov.* Saarela & B.A. Ford). Previous analyses of morphologic and molecular data indicate this wide-scaled clade is sister to the clade that includes the *C. jamesii* complex (Starr & Ford 2001).

To conduct the phylogenetic analysis, we used PAUP\* version 4.0b (Swofford 2000) on an Apple® computer. For this analysis, all characters were weighted equally. The most parsimonious tree was computed using an exhaustive search. We assessed the robustness of clades using decay and bootstrap analyses (10,000 replicates for the bootstrap analysis).

## RESULTS

**Morphology**

A scatter plot of the scores of principal components 1 and 2 depicts three distinct groups (Fig. 1). Component 1 provides separation of *C. jamesii* from *C. juniperorum*, while *C. timida* is separated on component 2. No subgroupings within these three groups are evident. Together, the first two components explain 71% of the variance within the data set, with component 1 accounting for 44% and component 2 accounting for 27%. The third principal component accounts for only 9.6% of the total variance and affords no separation of groups. All of the variables employed in the PCA have relatively high loadings (absolute values > 0.5) on at least one of the first two components (Table 2). The variables with the highest loadings on component 1 are CLMHT, LFSCL, and PERIGL, in descending order (abbreviations as in Table 1). On component 2, RSC, MSCL, and MARGW had the highest loadings. A plot of the two variables with the highest loadings for each component, CLMHT vs. RSC, separates the three groups (Fig. 2), but not as well as in the PCA plot.

Like the PCA, the ANOVA supports the existence of three groups in the *C. jamesii* complex. Though the measurements of many characters possess considerable variability and the ranges of the measurements overlap for many characters, at least two of the three groups have significantly different means for all 18 measured variables (Table 3). For eight of these characters, all three means are significantly different from each other. The variables that are the best for distinguishing the members of the *C. jamesii* complex, based on high *F* values, are RCLM, RSC, and MSCL, in descending order.

Each of the three species identified in the PCA and ANOVA is distinguished by several characters. Specimens with relatively high values for MSPL, MPDCLL, LFSCL, PERIGL, PERIGBKL, and RBK are referable to *Carex jamesii*, since its holotype falls within this group (Fig. 1). Plants with low values for CLMHT, MSCLL, MARGW, PERIGBKL, RCLM, and high values for LFNO and PERIGNO are *C. juniperorum*. A measured isotype of *C. juniperorum* is a member of this second group. The third group, with low values for MSPL, high for MSCL, and high for RSC, is *C. timida*. The specimen designated as holotype of *C. timida* is clearly in this third group.

Several qualitative characters also distinguish members of the *C. jamesii* complex. Plants of *C. juniperorum* and *C. timida* have red-purple tinging on their dark brown shoot bases, whereas plants of *C. jamesii* lack red-purple coloration. The cells of the cataphylls of specimens of *C. juniperorum* and *C. timida* are bulging (Fig. 3). However, in *C. jamesii*, the cataphylls have cell surfaces that are collapsed or flush with their anticlinal walls, at least in dried specimens. In living plants, *C. timida* is distinctive in the color of its foliage. Its leaves are lighter

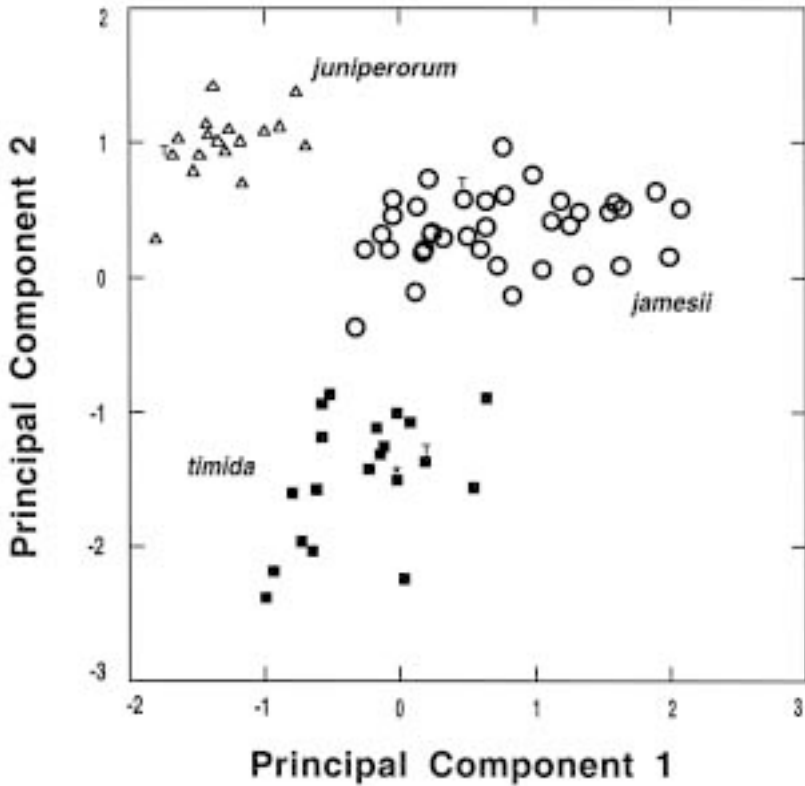

FIG. 1. Scatter plot of the scores of principal component 2 vs. principal component 1 from PCA of the measurements of members of the *Carex jamesii* complex. Circles represent specimens of *C. jamesii*, triangles represent *C. juniperorum*, and squares represent *C. timida*. The symbols adjacent to "T" represent type specimens. The asterisked square represents a specimen from the population that clusters with *C. juniperorum* in the study of genetic diversity of the *C. jamesii* complex (Ford & Naczi 2001).

green than those of *C. jamesii* and *C. juniperorum*. Also in living plants, the culms and leaves of *C. timida* are quite lax and spreading. Consequently, when perigynia are mature (and relatively heavy), most of the spikes are concealed by the foliage. The living culms of *C. jamesii* are more rigid, erect, and evident than those of *C. timida*. In *C. juniperorum*, the culms are erect and concealed by the greatly overtopping foliage (illustrated in Catling et al. 1993). The wider leaf blades of *C. juniperorum* have hyaline margins, whereas those of *C. jamesii* and *C. timida* are green. The proximalmost staminate scale in each spike has connate margins in *C. juniperorum* and *C. timida*, but the margins are free in *C. jamesii* (Fig 4). In addition, the staminate scales are papillate in *C. timida*, but nonpapillate in *C. jamesii* and *C. juniperorum* (Fig 5). In *C. timida*, some of the

TABLE 2. Loadings for the first two principal components from PCA of specimens of the *Carex jamesii* complex. Character abbreviations correspond to those in Table 1.

Character	Component 1	Component 2
CLMHT	0.89	-0.21
SHTHT	0.76	0.087
MPDCLL	0.72	0.089
MSCL	0.23	-0.90
LFSCCL	0.83	0.11
MARGW	0.58	-0.68
PERIGL	0.82	0.16
PERIGW	0.57	0.44
RSC	-0.20	-0.93

papillae are elongate and acute. Often these elongate papillae occur in pairs and resemble arthropod cerci.

Judging from the amount of scatter of points on the PCA plot (Fig. 1), the morphologic variability of *C. jamesii* and of *C. timida* is similar. Each of these species has substantially more variation than *C. juniperorum*. A specimen from the population of *C. timida* that clusters with *C. juniperorum* based on allozymes (Ford & Naczi 2001) is nested firmly within the *C. timida* group on the PCA plot (Fig. 1).

### Geography

*Carex jamesii* ranges widely, from northern New York and southern Ontario west to southeasternmost Minnesota and south to western South Carolina, northern Alabama, northern Mississippi, southern Arkansas, and southeasternmost Oklahoma (Fig. 6). It is very common in much of this region, but is rather rare east of Ohio, Kentucky, Tennessee, and Alabama.

*Carex juniperorum* occurs in three disjunct areas: southeastern Ontario, southwestern Virginia, and southern Ohio and adjacent northeastern Kentucky (Fig. 7). Except for the populations in southeastern Ontario, all populations of *C. juniperorum* are sympatric with *C. jamesii*. The southern Ohio and northeastern Kentucky populations of *C. juniperorum* are sympatric with *C. timida*. *Carex juniperorum* is local and quite rare, with populations known from only six counties.

*Carex timida* occurs disjunctly in three areas: the Ozark Mountains of southern Missouri and northern Arkansas, the Ouachita Mountains of southwestern Arkansas and southeastern Oklahoma, and southwestern Ohio and Indiana south to northern Alabama (Fig. 7). Throughout its range, *C. timida* is sympatric with *C. jamesii*. *Carex timida* is local and rare, with populations known from only 20 counties.

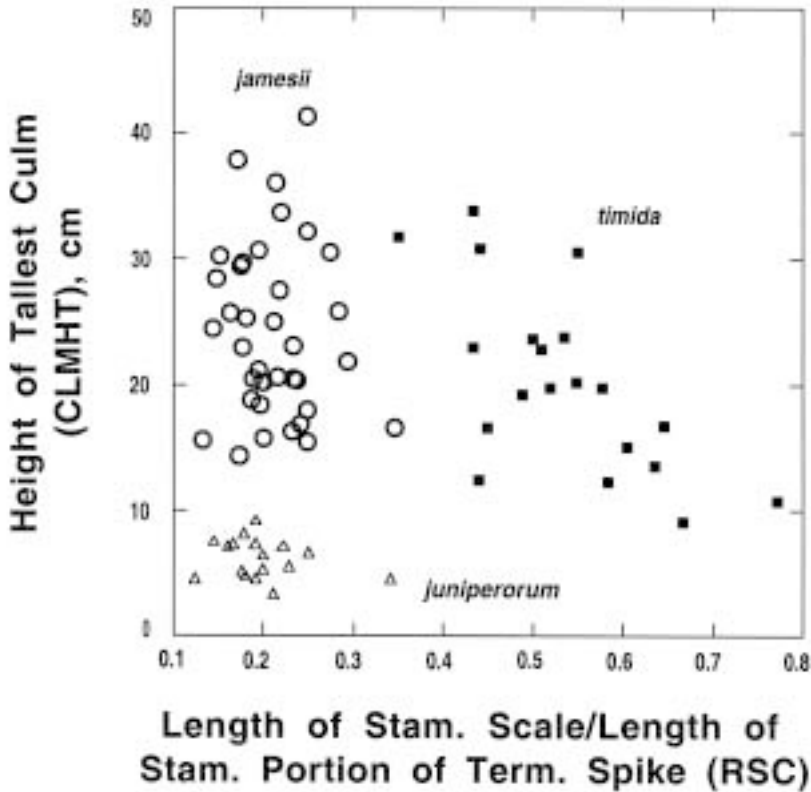

FIG. 2. Scatter plot of measurements of the variable having the highest loading on principal component 1 (height of tallest culm) vs. on component 2 [ratio of length of proximalmost staminate scale/length of longest (per specimen) staminate portion of terminal spike] for the members of the *Carex jamesii* complex. Circles represent specimens of *C. jamesii*, triangles represent *C. juniperorum*, and squares represent *C. timida*.

### Ecology

*Carex jamesii* plants inhabit mesic deciduous woodlands. They often grow along streams, usually in uplands, though they occasionally grow on floodplains. Substrates for *C. jamesii* are loams that appear to be calcareous and nutrient-rich, judging from the diverse associated flora, including known calciphiles. Some close associates of *C. jamesii* are *Acer saccharum* Marshall, *C. alburnsina* E. Sheld., *C. amphibola* Steud., *C. blanda* Dewey, *C. laxiculmis* Schwein. var. *copulata* (L.H. Bailey) Fernald, *C. oligocarpa* Willd., *C. rosea* Willd., *Cercis canadensis* L., *Diplazium pycnocarpon* (Spreng.) M. Broun, *Hydrastis canadensis* L., *Jeffersonia diphylla* (L.) Pers., *Lindera benzoin* (L.) Blume, *Osmorhiza longistylis* (Torr.) DC., *Podophyllum peltatum* L., *Polystichum acrostichoides* (Michx.) Schott, and



TABLE 3. Means  $\pm$  1 SD and ranges for morphologic characters measured for *Carex jamesii* complex. Character abbreviations correspond to those in Table 1. All measurements are in millimeters, except characters 14–16 (ratios) and characters 17–18 (counts).  $N$  = sample size. Within a row, means with different superscripts differ significantly (ANOVA,  $P < 0.03$ ).

Character	<i>C. jamesii</i> ( $N = 37$ )	<i>C. juniperorum</i> ( $N = 17$ )	<i>C. timida</i> ( $N = 20$ )	ANOVA $F$
1. CLMHT	239 <sup>a</sup> $\pm$ 68.7 (142–413)	61 <sup>b</sup> $\pm$ 16 (32–91)	202 <sup>a</sup> $\pm$ 73 (90–338)	120
2. SHTHT	385 <sup>a</sup> $\pm$ 91.6 (248–626)	271 <sup>b</sup> $\pm$ 90.2 (145–449)	314 <sup>b</sup> $\pm$ 74.7 (219–453)	13.2
3. WLFW	2.7 <sup>a</sup> $\pm$ 0.40 (1.8–3.5)	3.3 <sup>b</sup> $\pm$ 0.61 (2.2–4.2)	3.0 <sup>ab</sup> $\pm$ 0.73 (1.7–4.3)	7.0
4. MSPL	8.2 <sup>a</sup> $\pm$ 2.2 (4.9–13.5)	6.0 <sup>b</sup> $\pm$ 1.5 (3.6–8.4)	4.7 <sup>c</sup> $\pm$ 0.83 (3.4–6.2)	33
5. MPDCLL	1.9 <sup>a</sup> $\pm$ 0.7 (0.8–3.8)	0.7 <sup>b</sup> $\pm$ 0.4 (0.1–1.4)	1.1 <sup>c</sup> $\pm$ 0.4 (0.4–1.9)	30
6. MSCL	1.7 <sup>a</sup> $\pm$ 0.21 (1.1–2.1)	1.1 <sup>b</sup> $\pm$ 0.22 (0.9–1.6)	2.5 <sup>c</sup> $\pm$ 0.33 (1.9–3.3)	140
7. LFSCL	59 <sup>a</sup> $\pm$ 22 (31–119)	24 <sup>b</sup> $\pm$ 6.9 (16–36)	35 <sup>c</sup> $\pm$ 19 (17–81)	38
8. MARGW	0.5 <sup>a</sup> $\pm$ 0.1 (0.3–0.7)	0.1 <sup>b</sup> $\pm$ 0.06 (0.05–0.3)	0.6 <sup>c</sup> $\pm$ 0.09 (0.4–0.7)	100
9. PERIGL	6.1 <sup>a</sup> $\pm$ 0.75 (4.8–7.6)	4.6 <sup>b</sup> $\pm$ 0.38 (3.9–5.4)	5.0 <sup>b</sup> $\pm$ 0.46 (4.0–6.0)	44
10. PERIGW	2.1 <sup>a</sup> $\pm$ 0.16 (1.8–2.5)	1.9 <sup>b</sup> $\pm$ 0.14 (1.7–2.1)	1.9 <sup>b</sup> $\pm$ 0.15 (1.6–2.1)	19
11. PERIGBKL	2.9 <sup>a</sup> $\pm$ 0.51 (1.9–3.9)	1.6 <sup>b</sup> $\pm$ 0.24 (1.2–2.2)	2.0 <sup>c</sup> $\pm$ 0.27 (1.4–2.5)	77
12. ACHNL	2.4 <sup>a</sup> $\pm$ 0.24 (1.9–2.8)	2.2 <sup>b</sup> $\pm$ 0.14 (2.0–2.5)	2.3 <sup>ab</sup> $\pm$ 0.12 (2.1–2.5)	5.2
13. ACHNW	2.0 <sup>a</sup> $\pm$ 0.15 (1.8–2.4)	1.9 <sup>b</sup> $\pm$ 0.13 (1.6–2.1)	1.8 <sup>b</sup> $\pm$ 0.14 (1.6–2.1)	19
14. RCLM	0.62 <sup>a</sup> $\pm$ 0.095 (0.45–0.86)	0.23 <sup>b</sup> $\pm$ 0.050 (0.15–0.32)	0.63 <sup>a</sup> $\pm$ 0.12 (0.39–0.83)	190
15. RSC	0.21 <sup>a</sup> $\pm$ 0.045 (0.13–0.35)	0.20 <sup>a</sup> $\pm$ 0.048 (0.13–0.34)	0.54 <sup>b</sup> $\pm$ 0.10 (0.35–0.77)	160
16. RBK	0.47 <sup>a</sup> $\pm$ 0.038 (0.39–0.53)	0.35 <sup>b</sup> $\pm$ 0.029 (0.30–0.43)	0.39 <sup>c</sup> $\pm$ 0.029 (0.34–0.44)	85
17. LFNO	4 <sup>a</sup> $\pm$ 0.6 (3–6)	8 <sup>b</sup> $\pm$ 1 (6–11)	6 <sup>c</sup> $\pm$ 1 (4–8)	70
18. PERIGNO	3 <sup>a</sup> $\pm$ 0.7 (1–4)	6 <sup>b</sup> $\pm$ 1 (4–8)	3 <sup>a</sup> $\pm$ 0.5 (2–4)	90

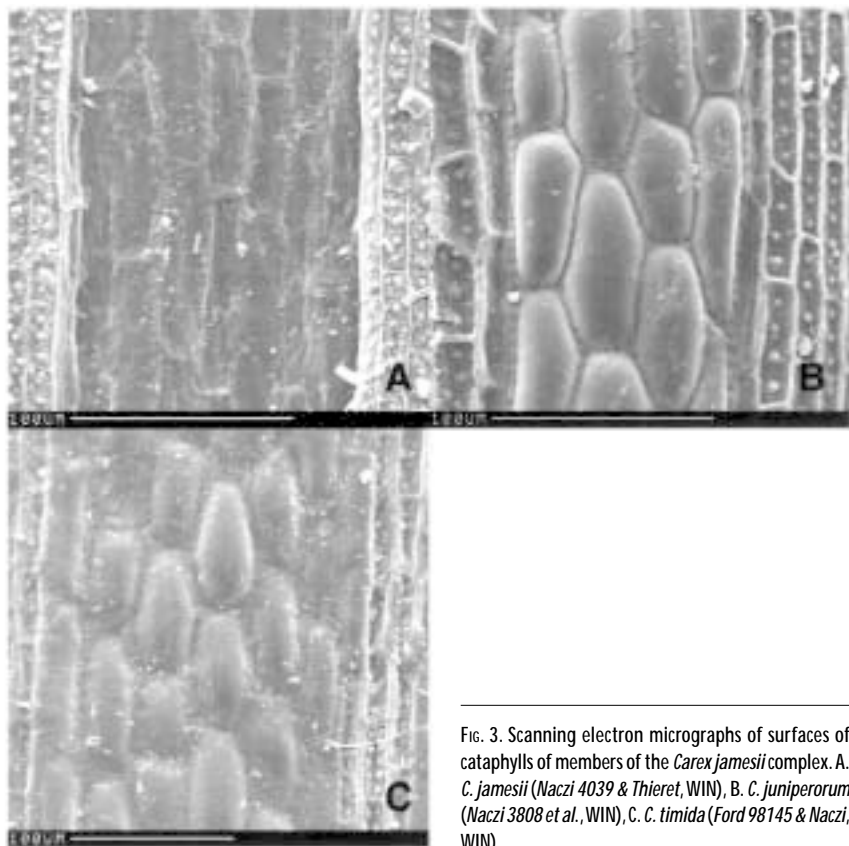

FIG. 3. Scanning electron micrographs of surfaces of cataphylls of members of the *Carex jamesii* complex. A. *C. jamesii* (Naczi 4039 & Thieret, WIN), B. *C. juniperorum* (Naczi 3808 et al., WIN), C. *C. timida* (Ford 98145 & Naczi, WIN).

*Sanguinaria canadensis* L. *Carex jamesii* rarely grows with *C. timida* (Table 4, and see below).

Plants of *Carex juniperorum* grow in mesic woodlands and edges of woodland openings, usually with a mixture of deciduous trees and junipers (*Juniperus virginiana* L.). Especially in Ontario, *C. juniperorum* occurs in juniper-dominated woodlands with few deciduous trees, particularly surrounding alvar openings (Catling et al. 1993). In the southern part of its range, *C. juniperorum* can be found in woodlands that are devoid of juniper. The optimal habitat, judging from the fact that specimens that are the most robust and produce the most perigynia grow in such places, appears to be mature, relatively open forests dominated by oaks and hickories, with few and scattered junipers. Usually, plants of *C. juniperorum* occur far from streams, particularly since they often grow on gentle slopes near hilltops. Its habitats are moist, at least during the early part of the growing season, often through groundwater seepage. Its

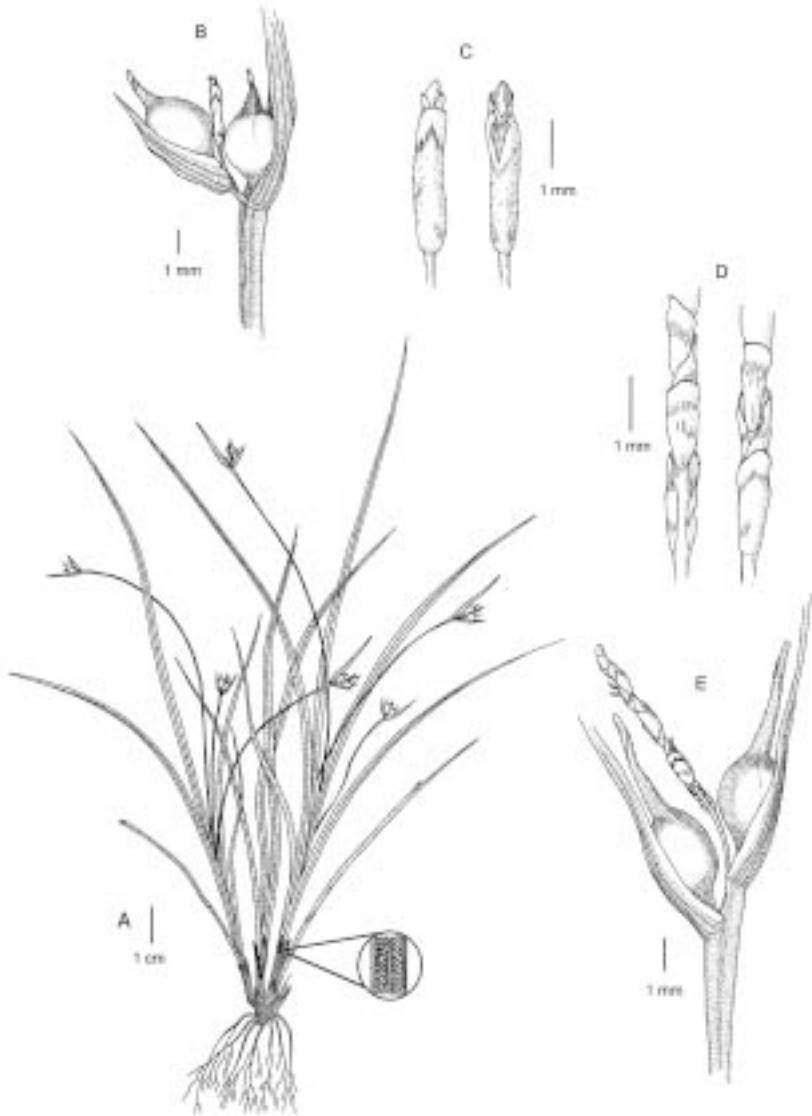

FIG. 4. *Carex timida* (A–C) and *C. jamesii* (D–E). *Carex timida*: A. Habit, with enlargement of portion of cataphyll, B. Terminal spike, C. Staminate portion of terminal spike, with proximalmost scale in abaxial view (left) and in adaxial view (right). *Carex jamesii*: D. Proximal region of staminate portion of terminal spike, with proximalmost scale in abaxial view (left) and in abaxial view (right). E. Terminal spike.

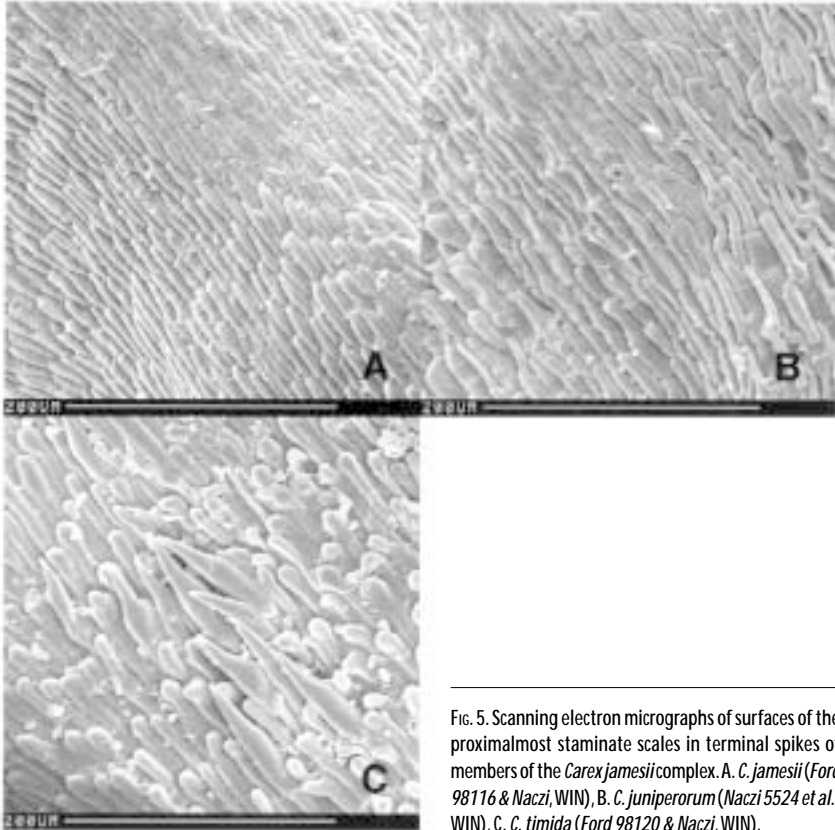

FIG. 5. Scanning electron micrographs of surfaces of the proximalmost staminate scales in terminal spikes of members of the *Carex jamesii* complex. A. *C. jamesii* (Ford 98116 & Naczi, WIN), B. *C. juniperorum* (Naczi 5524 et al., WIN), C. *C. timida* (Ford 98120 & Naczi, WIN).

substrates are clays that are calcareous and circumneutral (Catling et al. 1993) and usually are not rocky. Vascular plants closely associated with *C. juniperorum* include *Calystegia spithamea* (L.) Pursh, *Carex laxiflora* Lam., *C. oligocarpa*, *C. umbellata* Willd., *Cercis canadensis*, *Houstonia canadensis* Roem. & Schult., *Juniperus virginiana*, *Lithospermum canescens* (Michx.) Lehm., *Lobelia spicata* Lam., *Rhus aromatica* Aiton, and *Viburnum prunifolium* L. We have never observed *C. juniperorum* growing with any other member of the *C. jamesii* complex. Though rare and local, *C. juniperorum* is often common where it does occur.

The usual habitat of *Carex timida* is in relatively open (sometimes closed) mesic deciduous and deciduous-juniper woodlands. Populations often occur high on slopes and on hilltops, far from streams. The substrates are loams and clay-loams that are apparently calcareous. The substrates are often rocky, with limestone at or near the surface at several sites. Among the closely associated vascular plant species are *Acer saccharum*, *Aristolochia serpentaria* L., *Carex*

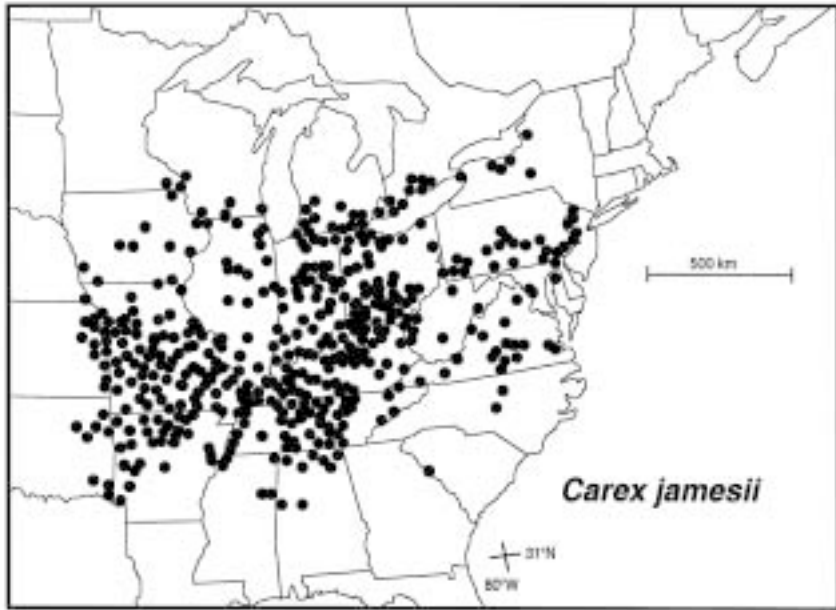

FIG. 6. Geographic distribution of *Carex jamesii*.

*blanda*, *C. cephalophora* Willd., *Carya* spp., *Cercis canadensis*, *Juniperus virginiana*, *Quercus* spp., and *Ulmus* spp. Of the nine sites for *C. timida* we have studied in the field, four of them also hosted *C. jamesii* (Table 4). When *C. timida* and *C. jamesii* are syntopic, *C. timida* usually grows higher on slopes in slightly drier microsites than *C. jamesii*.

### Phylogeny

We discovered 13 morphologic characters useful in the phylogenetic analysis of the *C. jamesii* complex (Table 5). Nine of the characters are reproductive and four are vegetative. Each of these characters has two states (Tables 5, 6). The analysis resulted in one most parsimonious tree that is 18 steps long (Fig. 8). The values for the consistency index and the retention index, excluding uninformative characters, are 0.67 and 0.64, respectively. Of the 13 characters employed in the phylogenetic analysis, 8 are nonhomoplasious, 2 are subject to parallelism between the *C. jamesii* complex and the outgroup (characters #4 and 7), and 3 are subject to reversal (#8, 10, and 12).

Five synapomorphies, three of which are nonhomoplasious, diagnose the *C. jamesii* complex and support its status as a monophyletic group (character numbers as in Table 5 in parentheses following the synapomorphy): relatively

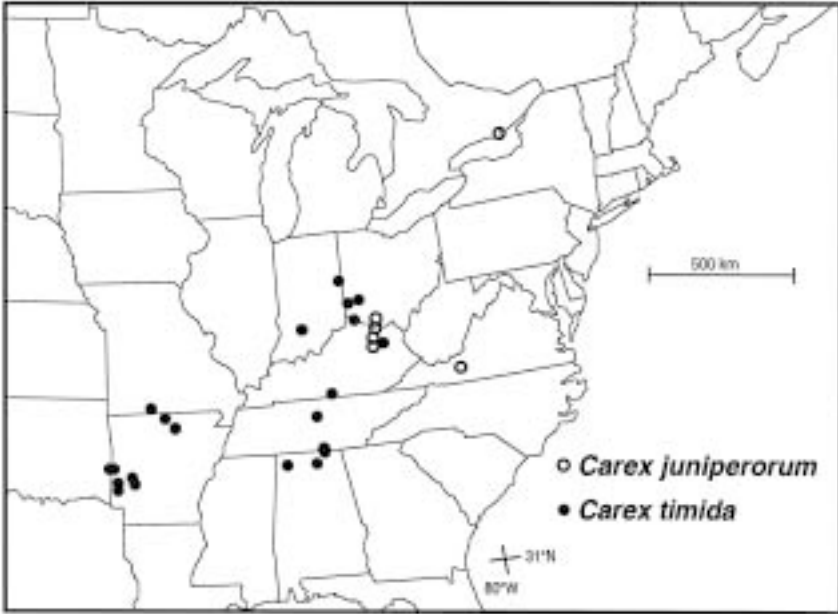

FIG. 7. Geographic distribution of *Carex juniperorum* and *C. timida*.

narrow staminate portions of the terminal spikes (6); relatively short proximalmost staminate scales (8), reversed in *C. timida*; truncate staminate scales (9); pistillate scales with hyaline margins relatively wide (12), reversed in *C. juniperorum*; and perigynia abruptly contracted to beaks (13). Two nonhomoplasious synapomorphies support the sister-group status of *C. juniperorum* and *C. timida*: shoot bases tinged with red-purple (1) and cataphyll cells bulging, Fig. 3 (3). Each of the three species in the *C. jamesii* complex is diagnosed by at least two autapomorphies. *Carex jamesii* has relatively long staminate portions of the spikes (5) and staminate scales with free margins, a reversal (10). *Carex juniperorum* is diagnosed by culms quite short relative to shoots (2), wider leaf blades with hyaline margins (4), a relatively high number of perigynia in the terminal spikes (7), and pistillate scales with the hyaline margins very narrow, a reversal (12). *Carex timida* has relatively long proximalmost staminate scales, a reversal (8), and staminate scales bearing papillae, some of which are elongate and acute (11). The clade of *C. jamesii* + *C. juniperorum* + *C. timida* has a decay value of 2 and has 78% bootstrap support, while the *C. juniperorum* + *C. timida* clade has a decay value of 1 and is supported in 51% of the bootstrap replicates.

TABLE 4. Examples of syntopy of *Carex jamesii* and *C. timida*. Numbers listed are Naczi's collection numbers for voucher specimens. Full specimen citations are provided in the taxonomic treatment.

Locality	<i>C. jamesii</i>	<i>C. timida</i>
Arkansas: Howard Co.	1925	1918, 1921
Kentucky: Campbell Co.	5649	5650
Kentucky: Monroe Co.	7236	7232
Ohio: Montgomery Co.	7363	7357

TABLE 5. Characters, character states, and character state polarizations discovered for use in the phylogenetic analysis of the *Carex jamesii* complex. The plesiomorphic state is indicated by "(0)" and the apomorphic state by "(1)." Abbreviations for characters included in the statistical analyses are as in Table 1.

- Shoot bases, color: lacking red-purple (0), tinged with red-purple (1).
- Culm, height of tallest per specimen/shoot bearing tallest culm, height (RCLM):  $\geq 0.39$  (0),  $\leq 0.32$  (1).
- Cataphylls, appearance of periclinal walls of epidermal cells, in dried specimens (Fig. 3): sunken or flush with anticlinal walls (0), bulging (1).
- Leaves, color of margins of wider blades: green (0), hyaline (1). The apomorphic state is due to complete sclerification of the margins (Starr & Ford 2001). *Carex latebracteata* and *C. saximontana* have hyaline leaf blade margins, but *C. backii* and *C. sp. nov.* lack them. Hyaline margins are scored as apomorphic since specimens in the likely sister groups to sect. *Phyllostachyae*, sects. *Fillifoliae* and *Firmiculmes* (Starr et al. 1999), have green margins.
- Staminate portion of terminal spikes, length of longest per specimen (MSPL):  $\leq 8$  mm (0),  $\geq 6$  mm (1).
- Staminate portion of terminal spikes, width:  $\geq 0.8$  mm (0),  $\leq 0.8$  mm (1). *Carex latebracteata* has the staminate portions of terminal spikes greater than 1 mm, but sometimes, *C. backii*, *C. saximontana*, and *C. sp. nov.* have them as narrow as 0.5 mm. However, most specimens of *C. backii*, *C. saximontana*, and *C. sp. nov.* have the staminate portions at least 0.8 mm wide. Thus, the plesiomorphic state is scored as staminate portions  $\geq 0.8$  mm wide.
- Perigynia in terminal spike, number (PERIGNO):  $\leq 5$  (0),  $\geq 5$  (1). *Carex latebracteata* usually has 7 or more perigynia in the terminal spike, which is likely a parallelism with the occurrence of this apomorphy in the *C. jamesii* complex since *C. backii*, *C. saximontana*, and *C. sp. nov.* usually have 5 or fewer perigynia per spike.
- Proximalmost staminate scale in terminal spikes, length (MSCL):  $\geq 2.0$  mm (0),  $\leq 2.0$  mm (1).
- Staminate scales, shape: ovate (0), truncate (1).
- Proximalmost staminate scale in terminal spikes, degree of fusion of margins: margins free (0), margins connate in basal 30–80% (0). *Carex latebracteata* has staminate scales with free margins, but *C. backii*, *C. saximontana*, and *C. sp. nov.* have scales with connate margins. Free margins are scored as plesiomorphic because specimens in the likely sister groups to sect. *Phyllostachyae*, sects. *Fillifoliae* and *Firmiculmes* (Starr et al. 1999), have scales with free margins.
- Staminate scales, appearance of periclinal walls of epidermal cells (Fig. 5): nonpapillate (0), papillate, with some papillae elongate and acute (1).
- Pistillate scale margins, width of hyaline portion of scale subtending distalmost perigynium of terminal spike (MARGW):  $\leq 0.3$  mm (0),  $\geq 0.3$  mm (1).
- Perigynia, abruptness of taper from bodies to beaks: gradually tapered (0), abruptly contracted (1).

TABLE 6. Character state assignments for members of the *Carex jamesii* complex. Characters and their states are as in Table 4. *Carex backii*, *C. latebracteata*, *C. saximontana*, and *C. n.sp.* constitute the outgroup.

	Character Number												
	1	2	3	4	5	6	7	8	9	10	11	12	13
<i>C. jamesii</i>	0	0	0	0	1	1	0	1	1	0	0	1	1
<i>C. juniperorum</i>	1	1	1	1	0	1	1	1	1	1	0	0	1
<i>C. timida</i>	1	0	1	0	0	1	0	0	1	1	1	1	1
<i>C. backii</i>	0	0	0	0	0	0	0	0	0	1	0	0	0
<i>C. latebracteata</i>	0	0	0	1	0	0	1	0	0	0	0	0	0
<i>C. saximontana</i>	0	0	0	1	0	0	0	0	0	1	0	0	0
<i>C. sp. nov.</i>	0	0	0	0	0	0	0	0	0	1	0	0	0

## DISCUSSION

The results of the PCA and ANOVA support the recognition of three distinct species in the *Carex jamesii* complex. The best diagnostic features are CLMHT, MSCL, RCLM, and RSC. Morphologically, the most divergent member of the *C. jamesii* complex is *C. juniperorum*. On both the PCA and bivariate plots, *C. juniperorum* is the most distinct of the three species (Figs. 1, 2). Of the 16 measured characters with statistically significantly different means that are extremes, 10 of them belong to *C. juniperorum* (Table 3). Measurements for 8 of these 10 characters represent low extremes. For measurements of only one character (MSPL) is *C. juniperorum* intermediate between *C. jamesii* and *C. timida*. *Carex juniperorum* is the only species with very short culms (CLMHT), very short peduncles on the staminate portions of spikes (MPDCLL), very short staminate scales (MSCL), very short pistillate scales (LFSCL), very narrow hyaline margins on its distal pistillate scales (MARGW), very short perigynium beaks (PERIGBKL), culms greatly overtopped by the leaves (RCLM), very short perigynium beaks relative to the length of the perigynia (RBK), a high number of leaves and bracts on reproductive shoots (LFNO), and a high number of perigynia in the terminal spikes (PERIGNO). *Carex juniperorum* is also the only species with hyaline margins on the wider leaves.

*Carex jamesii* is distinctive mostly in its high values for measured features. Of the 16 measured characters with statistically different means that are extremes, 10 of them belong to *C. jamesii* (Table 3). Measurements for 9 of these 10 characters represent high extremes. For measurements of only two characters (MSCL, MARGW) is *C. jamesii* intermediate between *C. juniperorum* and *C. timida*. *Carex jamesii* is the only species with very tall shoots (SHTHT), very long staminate portions of terminal spikes (MSPL), very long peduncles on the staminate portions of spikes (MPDCLL), very long pistillate scales (LFSCL), very long perigynia (PERIGL), very wide perigynia (PERIGW), very long perigynium



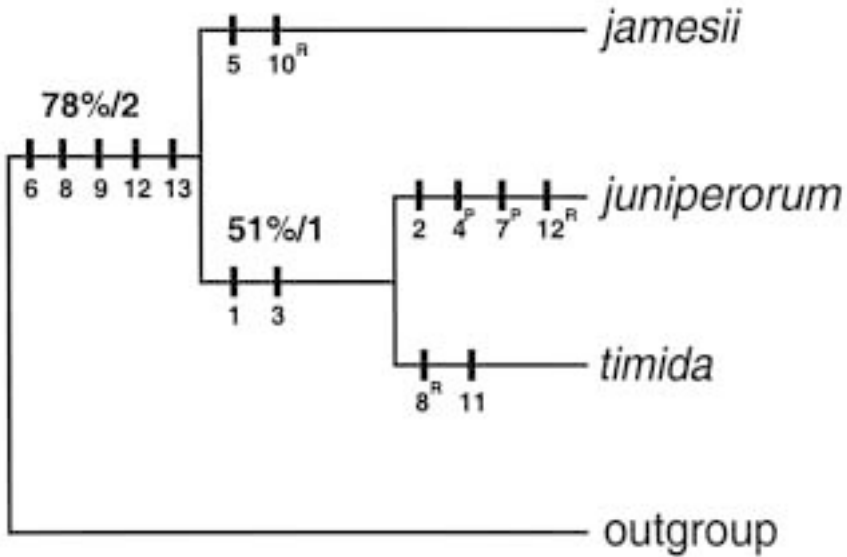

FIG. 8. The single most parsimonious tree resulting from the phylogenetic analysis of morphologic data of the *Carex jamesii* complex. The outgroup is composed of the "wide-scaled clade" of sect. *Phyllostachyae* (see Materials and Methods). The character state changes are represented by vertical bars (character numbers as in Table 5), with nonhomoplasious apomorphies indicated by unadorned character numbers, parallelisms with the outgroup indicated by superscript "P" on the character numbers, and reversals indicated by superscript "R." Bootstrap values and decay indices (following the slashes) are given above the branches.

beaks (PERIGBKL), very wide achenes (ACHNW), very long perigynium beaks relative to the length of the perigynia (RBK), and a low number of leaves and bracts on reproductive shoots (LFNO). Brown shoot bases, cataphylls with collapsed or flush cell surfaces, and staminate scales with free margins also distinguish *C. jamesii*.

The status of *C. timida* as a distinct species is less obvious than for *C. jamesii* and *C. juniperorum*. In five quantitative features (MPDCLL, LFSCCL, PERIGBKL, RBK, LFNO), *C. timida* is intermediate between *C. jamesii* and *C. juniperorum*. Of the 16 measured characters with statistically different means that are extremes, only 4 of them belong to *C. timida*. *Carex timida* is unique in having very short staminate portions of terminal spikes (MSPL), very long staminate scales (MSCL), very wide margins on the distalmost pistillate scale (MARGW), and proximalmost staminate scales that occupy a very high proportion of the length of the staminate portion of spikes (RSC). Qualitative features unique to *C. timida* include its lax culms and leaves, its relatively light green foliage, and its papillate staminate scales. While the features that distinguish *C. timida* are

less obvious than those of the other species in the complex, it does have several unique quantitative and qualitative morphologic features supporting its status as a species. We have chosen the epithet "timida" to highlight one of this species' morphologic qualities (lax culms usually hidden among the foliage and thus difficult to detect), but also because the true identity of *C. timida* had been undetected for so long.

The PCA and bivariate plots indicate that *C. jamesii* and *C. timida* are more phenetically similar to each other than either is to *C. juniperorum* (Figs. 1, 2). Yet, the phylogenetic analysis indicates that *C. juniperorum* and *C. timida* are sister species. The retained plesiomorphies of *C. jamesii* and *C. timida*, in combination with the apparently greater amount of anagenesis of *C. juniperorum* (as determined by it having twice as many autapomorphies as *C. jamesii* and *C. timida*), account for this discrepancy between phenetic and phylogenetic relationships. Genetic analysis of the *C. jamesii* complex also supports the sister-group status of *C. juniperorum* and *C. timida* (Ford & Naczi 2001).

The bootstrap and decay values indicate relatively weak support for the branches in the phylogenetic tree (Fig. 8). The consistency index (0.67) is relatively low, too, due to homoplasy. Given the relatively few morphologic characters available for phylogeny reconstruction in these reduced plants, the relatively weak support and moderate level of homoplasy are not unexpected. Despite relatively weak support for the tree generally, the monophyly of the *C. jamesii* complex is well-supported (5 character state changes, bootstrap value of 78%, and decay value of 2).

The presence of a greater amount of morphologic variability in *C. jamesii* and *C. timida* than in *C. juniperorum* is congruent with the results of genetic analysis of the *C. jamesii* complex (Ford & Naczi 2001). The reduced level of variation of *C. juniperorum* might be the result of morphologic features that limit gene flow (Ford & Naczi 2001). *Carex juniperorum* does have several characteristics that would seem to limit outcrossing and seed dispersal, such as very short culms, proximal pistillate scales that completely conceal the perigynia, and very short stigmas. It is surprising that *C. timida* would have a level of morphologic variation similar to the much more common and wider-ranging *C. jamesii*. Still, the geographic range of *C. timida* is large, and perhaps its relatively high morphologic variability results from diverse selection pressures and ecologic influences across its range.

One point of disagreement between the results of morphologic and genetic studies is in the relationships of plants from a population in Queen Wilhelmina State Park, Polk County, Arkansas. Ford & Naczi (2001) found these plants to group with *C. juniperorum*. Based on morphology, a specimen from this population is clearly *C. timida* (Fig. 1).

Each member of the *C. jamesii* complex has a unique geographic distribution. The limits of the range of *C. jamesii* are greater in all directions than the range

limits of the other two species, except the northeastern extreme. In this area, *C. juniperorum* ranges farther north than *C. jamesii*. *Carex juniperorum* is broadly sympatric with *C. jamesii*, though its range is disjunct. The range of *C. timida* is completely encompassed in the range of *C. jamesii*. *Carex timida* differs geographically from *C. jamesii* in being limited to three disjunct regions, while *C. jamesii* is relatively continuous across its range. The pattern of disjunction of *C. timida* is similar to several other vascular plant species. These species occur in the Ozark Mountains, the Ouachita Mountains, and in areas east of the Mississippi Embayment, but not intervening regions. Taxa sharing this pattern of disjunction include *C. ouachitana* Kral, Manhart, & Bryson (Naczi & Bryson 1990; McNeilus 1992), *C. willdenowii* Willd. (Naczi et al. 1998), *Castanea ozarkensis* Ashe (Johnson 1988; Nixon 1997), *Cotinus obovatus* Raf. (Little 1977), *Leptopus phyllanthoides* (Nutt.) G.L. Webster (Clark 1967; Smith 1988), *Magnolia tipetala* L. (Little 1977; Meyer 1997), *Monarda virgata* Raf. (Scora 1967; Smith 1988), and *Trillium pusillum* Michx. var. *ozarkanum* (Palmer & Steyerl.) Steyerl. (Cabe & Werth 1995). In a study of fish lineages with similar distribution patterns, Strange & Burr (1997) found different mechanisms may account for the disjunctions, including fragmentation of formerly widespread ranges by Pleistocene glaciations, dispersal events, and events that predated Pleistocene glaciations.

As with morphologic and geographic data, ecologic features distinguish the members of the *C. jamesii* complex. Ecologically, *C. juniperorum* is the most divergent member of the *C. jamesii* complex. It grows in the most open habitats with substrates having the highest clay content. It apparently does not occur with *C. jamesii* or *C. timida*, probably because of the distinctiveness of its habitat. *Carex jamesii* occurs in relatively moist sites in closed forest. *Carex timida* usually grows in slightly drier sites in more open forests, though it often grows near *C. jamesii*. The syntopic occurrences of *C. jamesii* and *C. timida* are significant because the two species probably overlap in flowering period and appear to have the opportunity to interbreed when syntopic. Our morphologic and genetic analyses revealed no evidence of hybrids. The fact that plants of such closely related species co-occur and maintain their distinctions is additional evidence of their status as separate species.

*Carex jamesii* is the most common member of the complex. In many parts of its range, it is one of the most common sedges of mesic deciduous forests. In contrast, *C. juniperorum* and *C. timida* are truly rare. Their rarity is reflected in the relative recency of their earliest collections. Whereas *C. jamesii* was collected at least as early as 1824 (the year of its description), the first known collection of *C. juniperorum* was in 1940 (originally identified as *C. jamesii*) and of *C. timida* in 1921 (again, originally identified as *C. jamesii*). Though additional collecting undoubtedly will reveal additional populations of these species, we recommend a range-wide review of their conservation status, with consideration for protection.

Though the eastern North American flora is relatively well-studied, it does continue to harbor undescribed species. As with *C. jamesii* in this study, morphologically distinctive species described early from northeastern North America have been a rich source of previously unsuspected diversity (Naczi et al. 1998). These species are often so distinctive and easy to identify that they are thought to be without taxonomic complexity until critically examined. Our expectation is that future studies of such species will yield more novelties, in sedges as well as in other plant groups.

#### TAXONOMIC TREATMENT

##### **Sectional Nomenclature**

Much confusion has surrounded determination of the correct name and authorship of the section to which the *Carex jamesii* complex belongs. Most modern authors (e.g. Mackenzie 1935; Fernald 1950; Gleason & Cronquist 1991) have used *Phyllostachyae* Tuck., but recent authors have followed Catling et al. (1993) in using *Phyllostachys* (J. Carey) L.H. Bailey.

Tuckerman (1843) was the first to apply an infrageneric name to the *C. jamesii* complex and its closest relatives. He used "*Phyllostachyae*" for three species, *C. backii*, *C. jamesii* (as *C. steudelii*), and *C. willdenowii*. Though Tuckerman attributed the name to Gray, Gray apparently did not publish *Phyllostachyae* himself. Tuckerman did not provide a description for *Phyllostachyae*, nor did he make its rank explicit. Christ (1885) used the name *Phyllostachyae* explicitly as a section for two European species, but again did not provide a description. It was not until 1909 that Kükenthal validly published the name *Phyllostachyae* at the sectional level.

Carey (1848) was the first to use the infrageneric name "*Phyllostachys*," for the same three species as Tuckerman, and attributed the name to Torrey and Gray. The attribution of the name to Torrey and Gray is probably because of their suggestion that *C. willdenowii* may belong to a genus separate from *Carex*, one "...to which the name *Phyllostachys* would be appropriate" (Torrey 1836: 404). While Carey described the infrageneric group he called *Phyllostachys*, he was not explicit about its rank. Apparently, Bailey (1885) was the first to explicitly assign the rank of section to the name *Phyllostachys*. He also listed the members of the section, designated its type, and divided the section into two "subordinate groups" (rank not explicit). Bailey placed six species in sect. *Phyllostachys*: *C. backii*, *C. geyeri* Boott, *C. jamesii* (as *C. steudelii*), *C. multicaulis* L.H. Bailey, *C. phyllostachys* C.A. Meyer, and *C. willdenowii*. He clearly designated *C. phyllostachys* the type of the section by stating, "...all but the type species exclusively American." Furthermore, he regarded *C. backii*, *C. jamesii*, and *C. willdenowii* as different enough from typical members of *Phyllostachys* to assign them to the "subordinate group" *Bractioideae*.

We regard *C. phyllostachys* as belonging to a section separate from *C. jamesii* and its closest relatives. *Carex phyllostachys* lacks the apical dilation of culms that characterizes the *C. jamesii* complex and its allies. In addition, *C. phyllostachys* has multinerved and vetricose perigynia, unlike the unnerved (but 2-ribbed), nonventricose perigynia in the *C. jamesii* complex and allies. Because Bailey used *C. phyllostachys* to typify sect. *Phyllostachys*, “*Phyllostachys*” cannot be used for the section that includes the *C. jamesii* complex. Instead, the correct name and authorship of the section that includes the *C. jamesii* complex is *Carex* sect. *Phyllostachyae* Tuck. ex Kük.

**Carex** section **Phyllostachyae** Tuck. ex Kük., Pflanzenz. IV. 20 (Hef 38):642. 1909.  
LECTOTYPE, here designated: *Carex jamesii* Schwein.

*Dapedostachys* Börner, Abh. Naturwiss. Vereine Bremen 21:265. 1913. TYPE: *Carex steudelii* Kunth.  
Non *Carex* section *Phyllostachys* (Torrey & A. Gray ex J. Carey) L.H. Bailey, Bot. Gaz. 10:208. 1885.  
TYPE: *Carex phyllostachys* C.A. Meyer.

### Identification Key to Members of the *Carex jamesii* Complex

Mature, complete, and ample specimens are necessary for correct identification of the members of the *Carex jamesii* complex.

1. Tallest culm 9.0–41 cm high, 39–86% of plant height; terminal spike with 1–4 perigynia; wider leaves with green margins; hyaline margins of distal pistillate scales 0.3–0.7 mm wide; perigynium beak 34–53% of perigynium length.
2. Longest (per plant) staminate portion of terminal spike 3.4–5.6(–6.2) mm long; proximalmost staminate scale in terminal spike (1.9–)2.1–3.3 mm long, (35–)44–77% of length of staminate portion of terminal spike; perigynium beaks 1.4–2.3(–2.5) mm long, 34–44% of perigynium length; shoot bases tinged with red-purple \_\_\_\_\_ **Carex timida**
2. Longest (per plant) staminate portion of terminal spike (4.9–)5.8–13.5 mm long; proximalmost staminate scale in terminal spike 1.1–1.8(–2.1) mm long, 13–26(–35)% of length of staminate portion of terminal spike; perigynium beaks (1.9–)2.3–3.9 mm long, 39–53% of perigynium length; shoot bases lacking red-purple \_\_\_\_\_ **Carex jamesii**
1. Tallest culm 3.2–9.1 cm high, 15–32% of plant height; terminal spike with 4–8 perigynia; wider leaves with hyaline margins 0.05–0.2 mm wide; hyaline margins of distal pistillate scales 0.05–0.3 mm wide; perigynium beak 30–38(–43)% of perigynium length \_\_\_\_\_ **Carex juniperorum**

### Species Accounts

**Carex jamesii** Schwein., Ann. Lyceum Nat. Hist. New York 1:67. 1824. TYPE: U.S.A. INDIANA. [no additional locality data provided], [no date provided], *James s.n.* (HOLOTYPE: PH\*); PROBABLE ISOTYPE: NY).

*Carex steudelii* Kunth, Enum. Pl. 2:480. 1837. *Dapedostachys steudelii* (Kunth) Börner ex Fedde & C. Schuster, Just's Bot. Jahresber. 41. II:9. 1918. TYPE: U.S.A. OHIO. [County unspecified, but in southwestern Ohio in the region drained by the Miami River (R.L. Stuckey, pers. comm.)]; Miami, 1835, *Frank s.n.* (HOLOTYPE: B, n.v., presumably destroyed; ISOTYPES: MO, NY). For historical background on this collection, see Stuckey (1974).

Perennial herb, densely caespitose. *Rhizomes* very short, 0.1–0.4 mm long between shoots or branches of the rhizomes, covered with cataphylls, with internodes 0.1–0.2 mm long and 1.2–1.9 mm thick. *Shoot bases* surrounded by cataphylls, dark brown or ferruginous to stramineous, lacking red-purple coloration. *Reproductive shoots* 12–63 cm tall, spreading; culms 5.7–41 cm tall, the tallest 14–41 cm high, slightly to moderately overtopped by the leaves, (0.45–)0.52–0.72(–0.86) of shoot height, 0.4–0.7 mm wide at midheight, smooth proximally and denticulate in distal half, acutely trigonous and three-winged, dilated just basal to terminal spike, 0.7–1.5 mm wide just basal to terminal spike. *Cataphylls* glabrous, multicostate, with cells with their outer walls sunken or flush with their anticlinal walls. *Leaves* 3–5(–6), blades 1.1–59 cm long, 1.2–3.1(–3.5) mm wide, the widest (1.8–)2.3–3.1(–3.5) mm wide, deep green, flat to barely plicate, glabrous, adaxial surface smooth or sparsely antrorsely scaberulous in distal portion, abaxial surface smooth; margins green, smooth or antrorsely scaberulous in distal portion; leaf sheaths 1.8–9.8 cm long, tight, glabrous; adaxial face of sheaths with hyaline band, hyaline band with apex subtruncate; ligules subtruncate to depressed-lingulate, 0.6–1.4 mm long. *Vegetative shoots* 13–57 cm tall; leaves like those of reproductive shoots; pseudoculms 3.3–9.9 cm tall, 1.1–2.6 mm wide at mid-height, 0.09–0.30 of shoot height. *Infructescence* a single terminal spike and (0–)1–3 lateral spikes. *Spikes* androgynous, simple, with staminate scales and perigynia spirally and densely imbricate. Terminal spike atop widely spreading to nodding culm, 6.4–15.7 mm long, 4.8–9.3 mm wide; staminate portion 2.4–10.3(–13.5) mm long, the longest (4.9–)6.0–10.3(–13.5) mm long, 0.4–0.7(–0.8) mm wide, 5–12-flowered, on peduncle 0.8–3.8 mm long; pistillate portion overlapping and usually exceed by staminate portion but sometimes slightly exceeding staminate portion, 6.4–11.3 mm long, 4.8–9.3 mm wide, (1–)2–3(–4)-flowered. Lateral spikes on widely spreading to nodding peduncles arising from base of culm; peduncles 2.7–14 cm long, capillary, flat, narrowly two-winged, dilated just basal to spike; spikes similar to terminal spikes except staminate portion 2.0–9.5 mm long. Proximalmost *staminate scale* of each terminal spike 1.1–1.9(–2.1) mm long, 0.13–0.26(–0.35) of length of staminate portion of terminal spike, 0.7–1.4 mm wide, short-cylindric, truncate or subtruncate (very broadly ovate), longitudinally 1-veined in basal 0.7, with longitudinal and narrow green band centered on vein, transversely brown-banded distal to apex of green band; margins free, overlapping base of adjacent distal staminate scale but not sheathing it, hyaline. Distalmost *pistillate scale* of each spike 3.8–21 mm long, 1.6–2.4 mm wide, ovate to lanceolate, acute and awnless but occasionally with awn to 5.9 mm long or longer scales leaf-like, center green and 4–9-veined, margins hyaline, whitish or whitish with brown band paralleling margin, hyaline margins (0.3–)0.4–0.7 mm wide. Proximalmost pistillate scale of each spike with morphology dependent on spike position; in terminal spikes, proximalmost scale leaf-like; in lateral spikes, proximalmost scale ovate

and awned or awnless. Proximalmost pistillate scale of terminal spikes 12–119 mm long, the longest 31–119 mm long; basal portions 1.6–2.9 mm wide, partially or completely concealing perigynia, green with hyaline margins, green portion 5–12-nerved, hyaline margins 0.05–0.3 mm wide; distal portions green, long-acuminate, with antrorsely scaberulous margins. Other pistillate scales, if present between proximalmost and distalmost scales, morphologically intermediate between distalmost and proximalmost scales. *Filaments* laminar, 0.20–0.30 mm wide, usually slightly wider than anthers. *Anthers* 3, 0.8–1.2 mm long. *Styles* jointed with summits of achenes, portions distal to achenes withering with age. *Stigmas* 3, 1.7–2.1 mm long, withering with age. *Perigynia* (4.8–) 5.4–6.8(–7.6) mm long, 1.8–2.3(–2.5) mm wide, (2.3–)2.5–3.3(–3.6) times as long as wide, (2.1–)2.4–3.0 times as long as achenes, ascending to spreading, subrotund to very broadly trigonous in cross-section, 2-ribbed, nerveless, glabrous, pale green to tan, narrowly ovoid to narrowly ellipsoid with obovoid body and compressed-deltoid beak; body tapered from widest point to subacute base, abruptly contracted to beak; beak (1.9–)2.3–3.4(–3.9) mm long, (0.39–)0.43–0.53 of perigynium length, straight, scaberulous on angles, apex entire. *Achenes* 1.9–2.8 mm long, 1.8–2.4 mm wide, 0.9–1.4 times as long as wide, tightly enveloped by perigynia, subrotund to very broadly trigonous in cross section, brown with 3 longitudinal paler brown lines that intersect at style base, subglobose, basally abruptly contracted to light tan stipe, beakless; stipes 0.3–0.4 mm long, 0.8–1.1 mm wide (Fig. 3A, 4, 5A).

Representative Specimens. Specimens marked with asterisks are those measured for statistical analyses. **CANADA. ONTARIO. Essex Co.:** Pelee Island, Fish Point, 25 Jun 1981, *Reznicek 6338* (MICH, MO, VPI, ctb). **Kent Co.:** Orford Township, Clear Creek, 22 May 1991, *Oldham 12554* (MICH\*). **Middlesex Co.:** 9 km ESE of Glencoe P.O., N side of Thames River, 29 May 1987, *Reznicek 7899* (MICH, MO, ctb\*). **Welland Co.:** 2.5 mi W of Port Colborne, near Rathfon Point, 1 Jul 1958, *Calder 23864* (MICH\*, MT, US). **U.S.A. ALABAMA. Madison Co.:** Huntsville, Monte Sano State Park, 8 May 1986, *Naczi 1020* (DOV). **Marshall Co.:** near Grant, near bottom of Fletcher's Hollow, 13 May 1939, *Harper 3728* (MICH\*, US). **Tuscaloosa Co.:** along Warrior River, ca. 0.25 mi above Lock 14, 10 May 1935, *Harper 3366* (MO, PH, US). **ARKANSAS. Benton Co.:** N of Bella Vista, 17 May 1986, *Castaner 9209* (MO, ctb). **Carroll Co.:** US highway 412 and Osage Creek, 24 May 1992, *Hyatt 4386.08* (MICH, ctb\*). **Cross Co.:** W of Birdeye, 20 May 1990, *Naczi 2449* (DOV, ctb). **Franklin Co.:** ca. 1 mi N of Cecil, 12 May 1989, *Naczi 2151* (DOV, ctb). **Howard Co.:** ca. 8 mi W of Umpire, N of route 4, along W side of Cossatot River, 17 May 1988, *Naczi 1925* (MICH\*). **Marion Co.:** Hand Valley at Ranchette (White River) Access Area, 1 May 1992, *Hyatt 4821.45* (MICH\*). **Montgomery Co.:** ca. 6 mi NW of Mount Ida, 20 May 1994, *Naczi 3935 & Ford* (DOV). **Scott Co.:** ca. 2 mi N of Y City, 10 May 1989, *Naczi 2128* (DOV, ctb). **Stone Co.:** ca. 3 mi ENE of Fifty Six, 21 May 1986, *Naczi 1206* (DOV). **DISTRICT OF COLUMBIA.** Washington and vicinity, 15 May 1896, *Steele s.n.* (MU\*). **ILLINOIS. Cook Co.:** Elk Grove, 28 May 1948, *Chase 9491* (NY). **Jackson Co.:** 5 mi SW of Murphysboro, 11 Apr 1976, *Solomon 1453* (MO). **Jo Daviess Co.:** 7.5 mi NW of Stockton, Apple River Canyon, 16 Jun 1937, *Hermann 8842* (NY). **Peoria Co.:** N of Princeville, 16 Jun 1897, *Chase 36* (MO, PH, US). **Pulaski Co.:** 2.1 mi SW of Olmsted, along E side of route 37, 26 May 1990, *Naczi 2488* (DOV\*, ctb). **Saline Co.:** ca. 7 mi ESE of Harrisburg, 20 May 1992, *Hyatt 4356* (MICH\*). **Winnebago Co.:** W of Rockford, 4 Jun 1954, *Fell 54303* (US). **INDIANA. Carroll Co.:** 5 mi E of Brookston, 8 Jun 1924, *Deam 40663* (NY). **Henry Co.:** 3 mi E of Mt. Summit, 24 May 1938, *Kriebel 5284* (NA). **Wabash Co.:** ca.

6 mi SW of Wabash, Asher Wood Nature Preserve, 21 May 1991, *Rothrock 2271* (ctb\*). **IOWA. Hardin Co.:** Near Eldora, along Iowa River, 3 Jun 1950, *Thorne 9619* (MT, US). **Johnson Co.:** McBride State Park, 25 May 1954, *Thorne 14072* (DHL, MT, NY). **Mills Co.:** Wilson Timber, T73N, R41W, section 24, 29 May 1992, *Wilson 5175* (MICH). **Story Co.:** Ames, 16 May 1938, *Weber 616* (MO, OS). **KANSAS. Linn Co.:** La Cygne Lake Park, along road to campground, 28 May 1994, *Reznicek 9819 & Reznicek* (MICH\*, ctb). **Miami Co.:** Miami County State Lake, 16 May 1964, *Harms 2046* (NY). **KENTUCKY. Barren Co.:** ca. 3 mi SSW of Haywood, Brigadoon State Nature Preserve, 14 Jun 1997, *Naczi 6472 & Heeg* (KNK\*). **Bath Co.:** 4 mi N of Salt Lick, 12 May 1999, *Naczi 7830* (DOV). **Calloway Co.:** Backusburg, W Fork Clarks River, 30 May 1973, *Athey 2332* (MUR). **Campbell Co.:** ca. 2 mi S of Alexandria, along E side of route 27, 5 Jun 1996, *Naczi 5649 et al.* (DOV\*). **Fayette Co.:** Lexington, 6 Jun 1942, *McFarland 93* (MO, NA, PENN, PH, TENN, US). **Graves Co.:** Folsomdale, 24 Apr 1972, *Athey 1608* (MUR, WKU). **Henderson Co.:** Henderson, Audubon State Nature Preserve, 14 Jun 1997, *Naczi 6477 & Heeg* (KNK\*). **Laurel Co.:** ca. 6 mi WNW of Bernstadt, along E side of Rockcastle River, 21 May 1998, *Naczi 7139 & Ford* (DOV\*). **Letcher Co.:** S from Whitesburg, just S of crest of Pine Mountain, 17 May 1994, *McKinney 6177* (DOV). **Madison Co.:** 5 mi SW of center of Richmond, 15 Jun 1998, *Naczi 7373 & Reznicek* (DOV\*). **Monroe Co.:** ca. 8 mi SE of Tompkinsville, S of route 216, 23 May 1998, *Naczi 7236 & Ford* (DOV). **Pendleton Co.:** 2 mi ESE of Falmouth, 3 Jun 1994, *Naczi 4039 & Thieret* (DOV, WIN, ctb). **MARYLAND. Cecil Co.:** 1.0 mi SE of Conowingo, 0.2 mi E of route 222 bridge, along Octoraro Creek, 29 May 1999, *Naczi 8051* (DOV\*). **Kent Co.:** N of Copeland, 6 Jun 2001, *McAvoy 5112* (DOV). **Montgomery Co.:** Croyley, along Potomac River, 4 May 1929, *Blake 10833* (MT, NA). **MICHIGAN. Allegan Co.:** 18 mi S of Grand Rapids, 18 Jun 1942, *Bazuin 4551* (KY). **Ingham Co.:** College Woods, [no day] Jun 1891, *C.F.Wheeler s.n.* (MICH\*). **Washtenaw Co.:** 4.75 mi S of Ann Arbor, 17 May 1938, *Hermann 9419* (NA, US). **Wayne Co.:** ca. 2.5 mi E of Belleville, Lower Huron Metropark, N side of Huron River, 24 May 1991, *Reznicek 8759 et al.* (MICH\*, VPI, ctb). **MINNESOTA. Fillmore Co.:** Forestville State Park, adjacent to South Branch Root River, 19 Jun 1984, *G.A. Wheeler 8361* (ctb\*). **Houston Co.:** Beaver Creek Valley State Park, 19 Jun 1984, *Wheeler 8391* (ctb). **MISSISSIPPI. Lowndes Co.:** 2 mi S of Artesia, 15 May 1989, *Bryson 8557* (ctb). **Oktibbeha Co.:** 2.5 mi E of Mississippi State University, 15 May 1989, *Bryson 8586 & Naczi* (OS, ctb). **Tishomingo Co.:** Yellow Creek Quad., Burns Hollow, 15 May 1979, *Rogers 46688* (TENN). **Tunica Co.:** ca. 11 mi S of Tunica, 24 Apr 1992, *Bryson 11400 & Newton* (MO, ctb). **MISSOURI. Boone Co.:** Columbia, Grindstone Park, 8 Jun 1996, *Reznicek 10184 et al.* (DOV, MICH). **Callaway Co.:** T47N, R8W, section 3, 24 Apr 1991, *Currier 91-004* (ctb\*). **Christian Co.:** 0.5 mi S of end of road FF, 27 Apr 1985, *Castaner 8265* (DOV). **Cooper Co.:** 0.9 mi N of junction of routes AE & Z, 21 May 1981, *Castaner 6380* (ctb\*). **Jackson Co.:** Independence, 2 Jun 1895, *Bush 709* (DOV, NY). **Schuyler Co.:** 3 mi E of Livonia, along E side of Chariton River, 1 Jul 1933, *Palmer 41061a & Steyermark* (MO). **Scott Co.:** 2.4 mi S of Blodgett, 0.6 mi S on main road into Fox Meadow Estates, 16 May 1992, *Jones 8546 & Jones* (MICH\*). **NEBRASKA. Richardson Co.:** SE of Rulo, along Nemaha River, 22 Jun 1940, *Reynolds 1450* (MO, NA). **NEW JERSEY. Hunterdon Co.:** Lambertville, foot of Goat Hill, near Delaware River, 31 May 1924, *Long 30383* (PH). **Mercer Co.:** N of Moore, 29 Apr 1922, *Mackenzie s.n.* (NY). **NEW YORK. Monroe Co.:** Near Honeoye Falls, 15 Jun 1941, *Matthews 4339* (KY, MICH, MO, MT, NA, PENN, TENN, US). **Tompkins Co.:** Ithaca, Six Mile Creek, 8 Jun 1919, *Wiegand 11595* (MICH, MO, MT, PENN, PH, US). **NORTH CAROLINA. Durham Co.:** 3 or 4 mi N of Durham, ca. 0.25 mi E of Old Oxford Road, along S side of Eno River, 8 May 1972, *Leonard 5440 & Moore* (KY, MO, MUR, MICH\*, TENN, VPI). **Lee Co.:** 2 mi W of Moncure, near Deep River, 3 Jun 1960, *Radford 43205* (KY, TENN). **OHIO. Butler Co.:** E of Miami University campus, E of Marcum Conference Center, 30 Apr 1991, *Vincent 4539* (MU\*). **Lawrence Co.:** 0.5 mi W of Burlington, 21 Apr 1992, *Cusick 30148* (MICH). **Montgomery Co.:** ca. 2 mi SW of Farmersville, ca. 0.2 mi E of Anthony Road, 0.3 mi SSW of junction of Anthony Road and Manning Road, 29 May 1998, *Naczi 7363 & Ford* (DOV\*). **OKLAHOMA. Cherokee Co.:** 7.5 mi NNE of Tahlequah, 13 May 1987, *Naczi 1591* (DOV). **Delaware Co.:** along N shore of Lake Eucha, 1.6 mi E of route 59/10, 25 May 1994, *Reznicek 9775 & Reznicek* (MICH\*, ctb). **McCurtain Co.:** ca. 9 mi NE of Broken Bow, 12 May 1987, *Naczi 1576* (DOV, MICH). **Muskogee Co.:** Braggs Hill Canyon, 6 May 1940, *Bebb 5163* (NA). **PENNSYLVANIA. Bedford**



**Co.:** 2.25 mi WNW of Everett, 17 Jun 1944, *Berkheimer 4920* (PENN, PH). **Berks Co.:** 0.75 mi W of Sinking Spring, 6 Jun 1943, *Berkheimer 3668* (PENN, PH, TENN). **Bucks Co.:** E of Ottsville, by Tincum Creek, 30 May 1925, *Long 32469* (PENN, PH). **Centre Co.:** Woodward, 6 Jun 1937, *Wahl 2539 & Clausen* (NA, US). **Franklin Co.:** ca. 1.5 mi WSW of Yeakle Mill, 7 May 1993, *Kunzman 10614* (PH). **Lancaster Co.:** Shenk's Ferry Ravine, 22 Jun 1940, *Tanger 3885* (PENN, PH). **Westmoreland Co.:** Near Saunders, Turtle Creek, 27 May 1933, *Bright 8838* (PENN). **SOUTH CAROLINA. McCormick Co.:** E of Savannah River, Stevens Creek Preserve, 17 Apr 1992, *Sorrie 6257 et al.* (bas). **TENNESSEE. Cannon Co.:** ca. 1.5 mi NE of Sugar Tree Knob Church, 3.0 mi W of TN 146, N side of Short Mountain Road, 3 May 1989, *Orzell & Bridges 9436* (MICH\*). **Cheatham Co.:** S of I-40 and TN 239 junction, above large truck park, 28 Apr 1993, *Kral 82118* (MICH\*, ctb). **Davidson Co.:** Nashville, 30 May 1990, *Naczi 2518A & Kral* (DOV). **DeKalb Co.:** 0.4 mi W on TN 141 from junction TN 96 at Center Hill Dam, 30 May 1988, *Thompson 88-617* (BEREA). **Dyer Co.:** NW of Dyersburg, 29 Apr 1949, *Sharp 12231 et al.* (TENN). **Franklin Co.:** Near Sherwood, 3 May 1941, *Shanks 1305* (TENN). **Obion Co.:** ca. 3.5 mi E of Ridgely, 27 Jun 1995, *Naczi 4852 & Reznicek* (DOV). **Perry Co.:** SE of Linden on old SR 13, E side of Buffalo River, 4 May 1993, *Kral 82279* (MICH\*, ctb). **Putnam Co.:** Caney Fork River, 27 Apr 1973, *Kral 49694* (MO, PH). **Rutherford Co.:** W of Murfreesboro, off highway 96, Scales Mountain, 26 Apr 1987, *McKinney 2420* (ctb\*). **Trousdale Co.:** ca. 3 mi N of Hartsville, 4 May 1973, *Kral 49794* (MO, PH). **VIRGINIA. Appomattox Co.:** Just N of Bent Creek, 11 Jun 1967, *Harvill 16519* (MO). **Bath Co.:** ca. 0.4 mi S of Healing Springs, 23 Jun 1994, *Naczi 4482 & Thieret* (DOV). **Fauquier Co.:** 2.5 mi below Thorofare Gap, 13 May 1945, *Allard 11243* (MT, PENN, VPI). **Lunenburg Co.:** ca. 13 mi SE of Lunenburg, along Flat Rock Creek, 3 Jun 1986, *Wieboldt 5982* (MICH, MO, VPI, ctb). **Prince George Co.:** By James River, Indian Point, 6 May 1940, *Fernald & Long 11768* (MO, PH, US). **Rockbridge Co.:** Natural Bridge, Cedar Creek, 30 May 1891, *Churchill 91* (MO). **Surry Co.:** Along James River, Claremont Wharf, 20 May 1939, *Fernald & Long 9862* (PH, US, VPI). **Wythe Co.:** Jackson's Ferry, 22 Jun 1940, *Hermann 10649* (NA). **WEST VIRGINIA. Cabell Co.:** Guyandotte, 13 Apr 1995, *Cusick 32274* (MICH, MO, MU, VPI, ctb). **Fayette Co.:** ca. 8 mi NE of Beckley, New River Gorge, 20 May 1985, *Wieboldt 5523* (MICH, VPI, ctb). **Mason Co.:** 0.5 mi down 16 Mile Creek Road (78), W of route 35, 22 May 1991, *Vincent 4707 & Hickey* (MU\*). **Pendleton Co.:** ca. 3.25 mi WNW of Cherry Grove, 23 May 1988, *Reznicek 8140 & Reznicek* (MICH, MO, VPI, ctb). **Wayne Co.:** Mouth of Big Creek, 6 May 1938, *MacFarland 4353* (NA). **WISCONSIN. Grant Co.:** T4N, R6W, sect. 15, 26 May 1979, *Tans 1920* (WIS). **Green Co.:** On "K" near Oakley store, 2 Jun 1958, *Fell 58-176* (WIS). **LaCrosse Co.:** Branch of Coon Creek in Bohemian Valley, 19 Jun 1959, *Hartley 6774* (WIS).

**Carex juniperorum** Catling, Reznicek, & Crins, Syst. Bot. 18:497. TYPE: CANADA. ONTARIO. HASTINGS CO.: 7 km NE of Shannonville, S side of hwy. 401, 9 Jun 1991, *Catling 9100* (HOLOTYPE: DAO, n.v.; ISOTYPES: KNK\*, MICH).

Perennial herb, densely caespitose. *Rhizomes* very short, 0.1–2.1 mm long between shoots or branches of the rhizomes, covered with cataphylls, with internodes 0.1–1.6 mm long and 1.3–1.9 mm thick. *Shoot bases* surrounded by cataphylls, dark red-purple to ferruginous, usually dark brown tinged with red-purple; red-purple coloration extending 17–68 mm above base of plant. *Reproductive shoots* 8.2–45 cm tall, spreading; culms 1.9–9.1 cm tall, the tallest 3.2–9.1 cm high, greatly overtopped by the leaves, 0.15–0.32 of shoot height, 0.3–0.7 mm wide at midheight, smooth except denticulate just basal to terminal spike, acutely trigonous and three-winged or occasionally four- or five-angled and four- or five-winged, dilated just basal to terminal spike, 0.8–1.3 mm wide just basal to terminal spike. *Cataphylls* glabrous, multicostate, with cells with their outer walls bulging. *Leaves* 6–11, blades 1.1–43 cm long, 0.7–4.2 mm wide, the

widest 2.2–4.2 mm wide, deep green, flat to barely plicate, glabrous, adaxial surface smooth or minutely papillate or sparsely antrorsely scaberulous in distal portion, abaxial surface smooth or minutely papillate; margins of wider blades hyaline, hyaline portions 0.05–0.2 mm wide; margins of narrower blades green; margins of all blades smooth or antrorsely scaberulous in distal portion; leaf sheaths 1.4–8.2 cm long, tight, glabrous; adaxial face of sheaths with hyaline band, hyaline band with apex truncate; ligules truncate to depressed-lingulate, 0–0.7 mm long. *Vegetative shoots* 9.8–45 cm tall; leaves like those of reproductive shoots; pseudoculms 1.3–5.6 cm tall, 1.1–3.7 mm wide at mid-height, 0.11–0.16 of shoot height. *Infructescence* a single terminal spike and (0–)1–3 lateral spikes. *Spikes* androgynous, simple, with staminate scales and perigynia spirally and densely imbricate. Terminal spike atop erect or ascending culm, 5.4–13.1 mm long, 4.9–8.8 mm wide; staminate portion 3.1–8.4 mm long, the longest 3.6–8.4 mm long, 0.4–0.9 mm wide, 8–17-flowered, on peduncle 0.1–1.4 mm long; pistillate portion overlapping and exceeding staminate portion or slightly exceeded by staminate portion, 5.4–9.4 mm long, 4.9–8.8 mm wide, 4–8-flowered. Lateral spikes on ascending to spreading peduncles arising from base of culm; peduncles 0.7–6.3 cm long, capillary, flat, narrowly two-winged, dilated just basal to spike; spikes similar to terminal spikes except staminate portion 1.7–2.9 mm long, pistillate portion (2–)4–6-flowered. Proximalmost *staminate scale* of each terminal spike 0.9–1.6 mm long, 0.13–0.25(–0.34) of length of staminate portion of terminal spike, 1.1–1.6 mm wide, short-cylindric, truncate or subtruncate (very broadly ovate), longitudinally 1-veined in basal 0.7–0.8, with longitudinal and narrow green band centered on vein, with green band narrowly bordered by dark brown; margins connate in basal 0.3–0.8, free apically, tightly sheathing adjacent distal staminate scales, hyaline. Distalmost *pistillate scale* of each spike 3.0–10.1 mm long, 1.1–1.5 mm wide, lanceolate, leaf-like, acute, awnless, green and 1–5-veined except for margins, margins hyaline, whitish, hyaline margins 0.05–0.2(–0.3) mm wide. Proximalmost pistillate scale of each spike leaf-like. Proximalmost pistillate scale of terminal spikes 12–36 mm long, the longest 16–36 mm long; basal portions 1.6–3.4 mm wide, completely concealing perigynia, green with hyaline margins, green portion 3–9-nerved, hyaline margins 0.05–0.2 mm wide; distal portions green, long-acuminate, with antrorsely scaberulous margins. Other pistillate scales morphologically intermediate between distalmost and proximalmost scales. *Filaments* laminar, 0.20–0.30 mm wide, usually slightly wider than anthers. *Anthers* 3, 1.1–1.7 mm long. *Styles* jointed with summits of achenes, portions distal to achenes withering with age. *Stigmas* 3, 0.8–1.2 mm long, withering with age. *Perigynia* (3.9–)4.2–5.0(–5.4) mm long, 1.7–2.1 mm wide, 2.0–2.6(–3.0) times as long as wide, 2.0–2.3 times as long as achenes, ascending to spreading, subrotund to very broadly trigonous in cross-section, 2-ribbed, nerveless, glabrous, pale green to tan, narrowly ovoid to narrowly ellipsoid with obovoid body and compressed-deltoid

beak; body tapered from widest point to subacute base, abruptly contracted to beak; beak (1.2–)1.4–1.8(–2.2) mm long, 0.30–0.38(–0.43) of perigynium length, straight, smooth or barely scaberulous on angles, apex entire. *Achenes* 2.0–2.5 mm long, 1.6–2.1 mm wide, 1.0–1.4 times as long as wide, tightly enveloped by perigynia, subrotund to very broadly trigonous in cross section, brown with 3 longitudinal paler brown lines that intersect at style base, subglobose, basally abruptly contracted to light tan stipe, beakless; stipes 0.3 mm long, 0.7–0.8 mm wide (Figs. 3B, 5B).

Representative Specimens. Specimens marked with asterisks are those measured for statistical analyses. **CANADA. ONTARIO. Hastings Co.:** 5.5 km NE of Shannonville, W of Salmon River, 11 Jun 1991, *Catling 9102* (MICH\*); 2 km SSW of Lonsdale, 13 Jun 1994, *Catling 20285 & Norris* (MICH\*). **U.S.A. KENTUCKY. Bath Co.:** Salt Lick, 12 May 1940, *McFarland 4799* (NA\*); 1 mi W of Polkville on US 60, "Blue Clays" on Fearing Road, 31 May 1991, *Campbell s.n.* (MICH\*); ca. 5 mi ESE of Owingsville, ca. 0.5 mi S of route 60, 0.3 mi E of Ore Mine Road, 16 May 1994, *Naczi 3890* (DOV\*, MICH, WIN, ctb). **Fleming Co.:** ca. 4 mi E of Hillsboro, along N side of route 1013, 28 May 1998, *Naczi 7321 & Ford* (DOV\*, MICH). **Lewis Co.:** 3.2 mi E of routes 10 & 57 junction in Tollesboro, S of route 10, 5 May 1994, *Naczi 3802 et al.* (DOV\*, VDB, WIN, ctb); ca. 3.5 mi ESE of Trinity, Hughes Knob, 5 May 1994, *Naczi 3808 et al.* (APSC, DOV\*, VDB, WIN, ctb); ca. 3.3 mi SW of Concord, N side of Crooked Creek Road, 30 May 1996, *Naczi 5524 et al.* (DOV\*, WIN); ca. 1 mi E of Concord, N side of route 8, 30 May 1996, *Naczi 5538 & Trauth* (APSC, DOV\*, MICH, VDB, VPI, WIN, ctb). **OHIO. Adams Co.:** 1.5 mi N of West Union on S side of Adams Lake, Adams Lake State Park, 6 May 1991, *Reznicek 8742 et al.* (MICH\*, OS); 3.5 mi NW of West Union, Chaparral Prairie Preserve, Hawk Hill Rd., 6 May 1991, *Reznicek 8744 et al.* (MICH\*); 3/5 mi S of Lynx, Lynx Prairie, 6 May 1991, *Reznicek 8748 et al.* (DOV\*, MICH, OS); 3 mi SW of Lynx, "Hanging Prairie" N of Black Run Rd., 6 May 1991, *Reznicek 8750 et al.* (MICH\*); ca. 3 mi NE of Peebles, S side of route 32, 16 May 1994, *Naczi 3878* (DOV\*, WIN, ctb). **VIRGINIA. Montgomery Co.:** Radford, Wildwood Park, W-facing slope above Connelly's Run, 9 Jun 1999, *Wieboldt 10214* (MICH\*, VPI).

**Carex timida** Naczi & B.A. Ford, sp. nov. TYPE: U.S.A. KENTUCKY. ROWAN CO.: ca. 6.5 mi S of center of Morehead, ca. 0.25 mi downslope from W side of route 1274, upslope from Sugar Camp Branch, ca. 1.3 road mi N of junction of routes 1274 and 801, 1 Jun 1996, *Naczi 5598 & Trauth* (HOLOTYPE: DOV\*; ISOTYPES: BRIT, CAN, DAO, EKY, F, GA, GH, IBE, KNK, KY, MDKY, MICH, MO, MU, NCU, NY, OS, PH, TENN, UARK, UNA, US, USCH, VDB, VPI, WIN, ctb).

A *Carex jamesii* basibus surculorum purpureis, rostris perigyniorum brevioribus differt; a *Carex juniperorum* culmis altioribus, laminis foliorum latorum viridimarginatis, spicis terminalibus 2–3(–4) perigyniis instructis, partibus hyalinis squamarum pistillarum distalibus 0.4–0.7 mm latis differt; a speciebus ambabus partibus staminatis spicarum brevioribus, squamis staminatis longioribus differt.

Perennial herb, densely caespitose. *Rhizomes* very short, 0.1–0.5 mm long between shoots or branches of the rhizomes, covered with cataphylls, with internodes 0.1–0.2 mm long and 1.4–1.8 mm thick. *Shoot bases* surrounded by cataphylls, dark red-purple to ferruginous, usually dark brown tinged with red-purple; red-purple coloration extending 34–47 mm above base of plant. *Reproductive shoots* 17–45 cm tall, spreading; culms 4.6–34 cm tall, the tallest 9.0–34 cm high, slightly to moderately overtopped by the leaves, (0.39–)0.59–0.83 of shoot height, 0.4–1.0 mm wide at midheight, smooth except denticulate just basal to terminal spike, acutely trigonous and three-winged, dilated just basal to terminal

spike, 0.7–1.3 mm wide just basal to terminal spike. *Cataphylls* glabrous, multicostate, with cells with their outer walls bulging. *Leaves* 4–6(–8), blades 4.1–35 cm long, 1.0–4.3 mm wide, the widest (1.6–)2.1–4.3 mm wide, medium green, flat to barely plicate, glabrous, adaxial surface smooth or sparsely antrorsely scaberulous in distal portion, abaxial surface smooth; margins green, smooth or antrorsely scaberulous in distal portion; leaf sheaths 1.3–6.9 cm long, tight, glabrous; adaxial face of sheaths with hyaline band, hyaline band with apex subtruncate to slightly convex; ligules subtruncate to depressed-lingulate, 0.2–1.8 mm long. *Vegetative shoots* 18–45 cm tall; leaves like those of reproductive shoots; pseudoculms 3.2–7.6 cm tall, 1.5–2.9 mm wide at mid-height, 0.14–0.20 of shoot height. *Infructescence* a single terminal spike and 1–3 lateral spikes. *Spikes* androgynous, simple, with staminate scales and perigynia spirally and densely imbricate. Terminal spike atop widely spreading to nodding culm, 6.8–8.8 mm long, 4.6–6.8 mm wide; staminate portion 2.4–5.6(–6.2) mm long, the longest 3.4–5.6(–6.2) mm long, 0.6–0.8(–1.0) mm wide, 2–12-flowered, on peduncle 0.4–2.3 mm long; pistillate portion overlapping and exceeding staminate portion or slightly exceeded by staminate portion, 6.8–8.5 mm long, 4.6–6.8 mm wide, 2–3(–4)-flowered. Lateral spikes on widely spreading to nodding peduncles arising from base of culm; peduncles 1.4–21 cm long, capillary, flat, narrowly two-winged, dilated just basal to spike; spikes similar to terminal spikes except staminate portion 1.4–4.2 mm long. Proximalmost *staminate scale* of each terminal spike (1.9–)2.1–3.3 mm long, (0.35–)0.44–0.65(–0.77) of length of staminate portion of terminal spike, 0.9–1.7 mm wide, short-cylindric, truncate or subtruncate (very broadly ovate), longitudinally 1-veined in basal 0.7, with longitudinal and narrow green band centered on vein, transversely brown-banded distal to apex of green band or with brown patch completely surrounding green band; margins connate in basal 0.3–0.8, free apically, tightly sheathing adjacent distal staminate scales, hyaline. Distalmost *pistillate scale* of each spike 3.1–8.6 mm long, 1.6–2.4 mm wide, ovate, usually acute and awnless but occasionally with awn to 2.3 mm long, center green and 3–7-veined, margins hyaline, whitish with brown band paralleling margin, hyaline margins 0.4–0.7 mm wide. Proximalmost *pistillate scale* of each spike with morphology dependent on spike position; in terminal spikes, proximalmost scale usually leaf-like, rarely like distalmost scale; in lateral spikes, proximalmost scale like distalmost scale. Proximalmost *pistillate scale* of terminal spikes 11–42(–81) mm long, the longest 17–42(–81) mm long; basal portions 1.6–2.1 mm wide, partially concealing perigynia, green with hyaline margins, green portion 5–12-nerved, hyaline margins 0.05–0.3 mm wide; distal portions green, long-acuminate, with antrorsely scaberulous margins. Other *pistillate scales*, if present between proximalmost and distalmost scales, morphologically intermediate between distalmost and proximalmost scales. *Filaments* laminar, 0.15–0.20 mm wide, usually slightly wider than anthers. *Anthers* 3, 0.4–1.5 mm long. *Styles* jointed

with summits of achenes, portions distal to achenes withering with age. *Stigmas* 3, 1.4–1.6 mm long, withering with age. *Perigynia* (4.0–)4.4–5.6(–6.0) mm long, 1.6–2.1 mm wide, (2.2–)2.5–3.1 times as long as wide, 1.9–2.4 times as long as achenes, ascending to spreading, subrotund to very broadly trigonous in cross-section, 2-ribbed, nerveless, glabrous, pale green to tan, narrowly ovoid to narrowly ellipsoid with obovoid body and compressed-deltoid beak; body tapered from widest point to subacute base, abruptly contracted to beak; beak (1.4–)1.7–2.3(–2.5) mm long, 0.34–0.44 of perigynium length, straight, scaberulous on angles, apex entire. *Achenes* 2.1–2.5 mm long, 1.6–2.1 mm wide, 1.0–1.4 times as long as wide, tightly enveloped by perigynia, subrotund to very broadly trigonous in cross section, brown with 3 longitudinal paler brown lines that intersect at style base, subglobose, basally abruptly contracted to light tan stipe, beakless; stipes 0.3–0.5 mm long, 0.7–0.9 mm wide (Figs. 3C, 4, 5C).

Additional Specimens Examined. Specimens marked with asterisks are those measured for statistical analyses. **U.S.A. ALABAMA. Colbert Co.:** ca. 4 mi S of Tusculumbia, N slope of Little Mountain, 31 Mar 1935, *Harper 3325* (MO, NY\*, PH, US). **Jackson Co.:** 9 mi S of Huntland [Tennessee], by Ala. 65, 28 Apr 1972, *Kral 45800* (MO, ctb\*). **Madison Co.:** Near Huntsville, W slope of Monte Sano Mountain, 14 Apr 1935, *Harper 3331* (MO, NY, PH, US); E Huntsville, Mt. Monte Sano, along Bankhead Parkway, 2 May 1974, *Bryson 492* (ctb); E side of Huntsville, summit of Monte Sano Mountain, along entrance drive to Monte Sano State Park, 25 May 1998, *Naczi 7264 & Ford* (DOV\*, MICH, VDB, WIN, ctb). **ARKANSAS. Baxter Co.:** Clifty Canyon Botanical Area, Ozark National Forest, T17N, R12W, NE 1/4 of section 33, 14 Apr 1992, *Hyatt 4528.03* (MICH\*), T17N, R12W, NW 1/4 of section 32, 30 Apr 1992, *Hyatt 4815.03* (VDB). **Howard Co.:** To NE of Cossatot River and Arkansas highway 4 crossing, 10 May 1986, *Bryson 4333* (MICH, VDB, ctb); ca. 8 mi W of Umpire, N of route 4, along W side of Cossatot River, 17 May 1988, *Naczi 1918* (MICH\*), 17 May 1988, *Naczi 1921* (MICH). **Montgomery Co.:** Ouachita National Forest, ca. 0.2 mi W of Little Missouri Trail's W end, along Blaylock Creek, T4S, R27W, SE 1/4 of SE 1/4 of section 29, 15 Apr 1996, *Hyatt 6937* (MICH\*). **Pike Co.:** Ouachita National Forest, along Little Missouri River, SW of Raven Creek, T5S, R27W, N edge of section 5, 19 Apr 1997, *Hyatt 7343* (DOV, MICH\*). **Polk Co.:** Blackfork Mountain, in ravine NE of Little Cemetery, T1N, R32W, W1/2 of SE1/4 of section 26, 4 May 1982, *Rettig 503* (VDB), 4 May 1982, *Rettig 504* (VDB); Along Cossatot River above route 246 bridge, 3 May 1983, *Rettig 810* (VDB), *Rettig 825B* (VDB), 10 May 1986, *Bryson 4323* (IBE, MICH, MO, TENN, VDB, ctb), 12 May 1987, *Naczi 1579* (DOV), 14 May 1987, *Castaner 9681* (MO, ctb), 13 May 1990, *Jones 4648 & Jones* (MICH, MO, VDB, ctb), 18 May 1993, *Jones 10139 & Jones* (MICH, VPI\*), 20 May 1994, *Naczi 3949 & Ford* (DOV); Queen Wilhelmina State Park, below and to N of visitor center and Arkansas highway 88, T1S, R32W, section 11, 10 May 1986, *Bryson 4287* (MICH, MO, TENN, VDB, ctb), 11 May 1989, *Naczi 2137* (DOV\*, ctb), 20 May 1994, *Naczi 3940 & Ford* (DOV). **Stone Co.:** ca. 2 mi NW of Fifty-six, Ozark National Forest, Sylamore Ranger District, T16N, R12W, section 27, 28 Jun 1993, *Hyatt 5653* (VDB). **INDIANA. Jay Co.:** 2 mi SE of Boundary, 14 May 1921, *Deam 33879* (NY, PH\*). **Lawrence Co.:** Bedford, Wilson Park, along Spider Creek, 5 Jun 1934, *Kriebel 1768* (PH\*). **KENTUCKY. Campbell Co.:** ca. 2 mi S of Alexandria, along E side of route 27, 5 Jun 1996, *Naczi 5650 et al.* (DOV\*). **Monroe Co.:** ca. 8 mi SE of Tompkinsville, S of route 216, 23 May 1998, *Naczi 7232 & Ford* (DOV\*, MICH, MU, TENN, USCH, VDB, VPI, WIN, ctb), *Ford 98100 & Naczi* (WIN). **Rowan Co.:** Type locality, 28 May 1998, *Naczi 7313 & Ford* (DOV, WIN), *Ford 98145 & Naczi* (WIN). **MISSOURI. Taney Co.:** 6 mi SE of Protem, 4 mi S of Ocie, in Big Cedar Hollow, just W of Taney Co. line, section 18, 30 Apr 1938, *Steyermark 5303* (MO, NA\*). **OHIO. Montgomery Co.:** E, Anthony Road, 0.3 mi SSW, junction of Manning Road, NE1/4, section 5, German Twp., 14 May 1985, *Cusick 25229* (MU\*), ca. 2 mi SW of Farmersville, ca. 0.2 mi E of Anthony Road, 0.3 mi SSW of junction of Anthony Road and Manning Road, 29 May 1998, *Naczi*

7357 & Ford (DOV, MICH, WIN, ctb), Ford 98153 & Naczi (WIN). **[Preble or Butler Co.]**: N of Oxford, E Hueston's woods, 20 May 1934, *Belk s.n.* (MU\*). **OKLAHOMA. LeFlore Co.**: NW and below State Line Historical Site, N of Oklahoma highway 1, 10 May 1986, *Bryson 4307* (MICH\*, MO, VDB, ctb). **TENNESSEE. Franklin Co.**: Huntland, 3 May 1939, *Svenson 10036* (TENN); 2.6 mi S of Huntland, 28 Apr 1972, *Kral 45837* (MO, VDB), 24 May 1998, *Naczi 7242 & Ford* (DOV\*, MICH, TENN, USCH, VDB, VPI, WIN, ctb), *Ford 98108 & Naczi* (WIN). **Wilson Co.**: Cedars of Lebanon State Park, 28 May 1989, *McNeilus 89-287* (IBE, MICH\*, MO, TENN, VDB, ctb).

#### ACKNOWLEDGMENTS

We thank Charles T. Bryson and Patrick J. Calie for valuable comments on the manuscript through their reviews. We also thank Charles T. Bryson, Anton A. Reznicek, Amy Trauth-Nare, Robert Kral, and John W. Thieret for assistance with field work. William A. McAvoy, Bruce A. Sorrie, and Thomas F. Wieboldt generously allowed us to publish information on their noteworthy collections. Curators of BERE, BLH, DHL, DOV, EKY, IBE, KNK, KY, MICH, MO, MT, MU, MUR, NA, NY, OS, PENN, PH, TENN, US, VDB, VPI, WIN, WKU; and Charles T. Bryson and Bruce A. Sorrie loaned specimens or assisted us during our visits. Theodore S. Cochrane supplied information on specimens of *Carex jamesii* at WIS. Thomas J. Reaume drew *Carex timida* and *C. jamesii*. The Kentucky State Nature Preserves Commission permitted collection at some of its preserves. National Science Foundation Doctoral Dissertation Improvement Grant BSR-9001260 (to RFCN), Natural Sciences and Engineering Research Council of Canada operating and equipment grants (to BAF), grants from the Horace H. Rackham School of Graduate Studies of the University of Michigan (to RFCN), and a small grant from the Kentucky State Nature Preserves Commission (to RFCN) provided financial support for portions of this work.

#### REFERENCES

- BAILEY, L.H. 1885. Notes on *Carex*—III. Bot. Gaz. 10:203–208.
- CABE, P.R. and C. WERTH. 1995. The *Trillium pusillum* Michaux (Liliaceae) complex in Virginia. II. Isozyme evidence. Castanea 60:15–29.
- CAREY, J. 1848. *Carex* L. In: Gray, A., A Manual of the Botany of the Northern United States, from New England to Wisconsin and South to Ohio and Pennsylvania Inclusive. James Munroe & Co., Boston. Pp. 535–567.
- CATLING, P.M., A.A. REZNICEK, and W.J. CRINS. 1993. *Carex juniperorum* (Cyperaceae), a new species from northeastern North America, with a key to *Carex* sect. *Phyllostachys*. Syst. Bot. 18:496–501.
- CHRIST, H. 1885. Nouveau catalogue des *Carex* D'Europe. Bull. Soc. Roy. Bot. Belgique 24. II:10–20.
- CLARK, R. C. 1967. *Andrachne phyllanthoides* (Nuttall) Muell. on the Cumberland Plateau of Alabama. Castanea 32:73–74.
- CRINS, W.J. 1990. Phylogenetic considerations below the sectional level in *Carex*. Canad. J. Bot. 68:1433–1440.

- FERNALD, M.L. 1950. Gray's manual of botany, 8th ed. American Book Co., New York, NY.
- FORD, B.A., D.A.R. McQUEEN, R.F.C. NACZI, and A.A. REZNICEK. 1998a. Allozyme variation and genetic relationships among species in the *Carex willdenowii* complex (Cyperaceae). *Amer. J. Bot.* 85:546–552.
- FORD, B.A., D.A.R. McQUEEN, J.R. STARR, and R.F.C. NACZI. 1998b. The impact of species-specific traits and phylogenetic relatedness on allozyme diversity in *Carex* section *Phyllostachys* (Cyperaceae). *Pl. Syst. Evol.* 212:13–29.
- FORD, B.A. and R.F.C. NACZI. 2001. Genetic diversity in the *Carex jamesii* complex (Cyperaceae: sect. *Phyllostachyae*), with insights into the evolution and origin of the newly described species *Carex timida*. *Sida* 19:885–897.
- FORD, B.A., J.R. STARR, D.A.R. McQUEEN, and R.F.C. NACZI. 1998c. Relationships among species in *Carex* section *Phyllostachys* (Cyperaceae) based on allozyme divergence. *Pl. Syst. Evol.* 212:31–51.
- GLEASON, H.A. and A. CRONQUIST. 1991. Manual of vascular plants of northeastern United States and adjacent Canada, 2d ed. New York Botanical Garden, Bronx, NY.
- HOLMGREN, P.K., N.H. HOLMGREN, and L.C. BARNETT [eds.]. 1990. Index herbariorum part I. The herbaria of the world, 8th ed. New York Botanical Garden, Bronx, NY.
- JOHNSON, G.P. 1988. Revision of *Castanea* sect. *Balanocastanon* (Fagaceae). *Journal of the Arnold Arboretum* 69:25–49.
- LITTLE, E.L. 1977. Atlas of United States trees, vol. 4. United States Government Printing Office, Washington, DC.
- MCNEILUS, V.B. 1992. *Carex ouachitana* (Cyperaceae) new to Tennessee. *Sida* 15:154–155.
- MACKENZIE, K.K. 1935. Cyperaceae - Cariceae. *N. Amer. Fl.* 18:169–478.
- MEYER, F.G. 1997. *Magnolia*. In: Flora of North America Editorial Committee, eds. Flora of North America North of Mexico, Vol. 3. Magnoliophyta: Magnoliidae and Hamamelidae. Oxford Univ. Press, New York. Pp. 4–10.
- NACZI, R.F.C. 1999. Chromosome numbers of some eastern North American species of *Carex* and *Eleocharis* (Cyperaceae). *Contr. Univ. Michigan Herb.* 22:105–119.
- NACZI, R.F.C. and C.T. BRYSON. 1990. Noteworthy records of *Carex* (Cyperaceae) from the southeastern United States. *Bartonia* 56:49–58.
- NACZI, R.F.C. and B.A. FORD. 1998. Systematics of the *Carex jamesii* complex (section *Phyllostachys*, Cyperaceae). *Suppl. to Amer. J. Bot.* 85:147.
- NACZI, R.F.C., A.A. REZNICEK, and B.A. FORD. 1998. Morphological, geographical, and ecological differentiation in the *Carex willdenowii* complex (Cyperaceae). *Amer. J. Bot.* 85:434–447.
- NIXON, K.C. 1997. *Castanea*. In: Flora of North America Editorial Committee, eds. Flora of North America North of Mexico, Vol. 3. Magnoliophyta: Magnoliidae and Hamamelidae. Oxford Univ. Press, New York. Pp. 439–442.
- SCORA, R.W. 1967. Interspecific relationships in the genus *Monarda* (Labiatae). *Univ. Calif. Publ. Bot.* 41:1–59.
- SMITH, E.B. 1988. An atlas and annotated list of the vascular plants of Arkansas, 2nd ed. By the author, Fayetteville, Ark.

- STARR, J.R., R.J. BAYER, and B.A. FORD. 1999. The phylogenetic position of *Carex* section *Phyllostachys* and its implications for phylogeny and subgeneric circumscription in *Carex* (Cyperaceae). *Amer. J. Bot.* 86:563–577.
- STARR, J.R. and B.A. FORD. 1995. Phylogeny and character evolution in *Carex* section *Phyllostachys*. *Suppl. to Amer. J. Bot.* 82:164–165.
- STARR, J.R. and B.A. FORD. 2001. The taxonomic and phylogenetic utility of vegetative anatomy and fruit epidermal silica bodies in *Carex* section *Phyllostachys* (Cyperaceae). *Canad. J. Bot.* 79:362–379.
- STARR, J.R., B.A. FORD, and R.J. BAYER. 1997. Testing phylogenetic hypotheses in *Carex* (Cyperaceae) using sequences from the internal transcribed spacer (ITS) region of nrDNA. *Suppl. to Amer. J. Bot.* 84:235.
- STRANGE, R.M. and B.M. BURR. 1997. Intraspecific phylogeography of North American highland fishes: a test of the Pleistocene vicariance hypothesis. *Evolution* 51:885–897.
- STUCKEY, R.L. 1974. Dr. Joseph C. Frank's botanical work in Ohio, with a list of his 1835 type specimens of vascular plants in American herbaria. *Castanea*. 39:263–272.
- SWOFFORD, D.L. 2000. PAUP\*: Phylogenetic Analysis Using Parsimony (\* and Other Methods), version 4.0. Sinauer, Sunderland, Massachusetts.
- TORREY, J. 1836. Monograph of North American Cyperaceae. *Ann. Lyceum Nat. Hist. New York* 3:239–448.
- TUCKERMAN, E. 1843. *Enumeratio methodica caricum quarundam*. Schenectady, New York.
- WILKINSON, L. 1989. SYSTAT: the system of statistics. SYSTAT, Evanston, IL.